

ERP Course: Service Coordination Protocols

Readings: Chapter 7 from Gustavo Alonso et al

Peter Dolog
dolog [at] cs [dot] aau [dot] dk
5.2.03
Information Systems
November 13, 2008

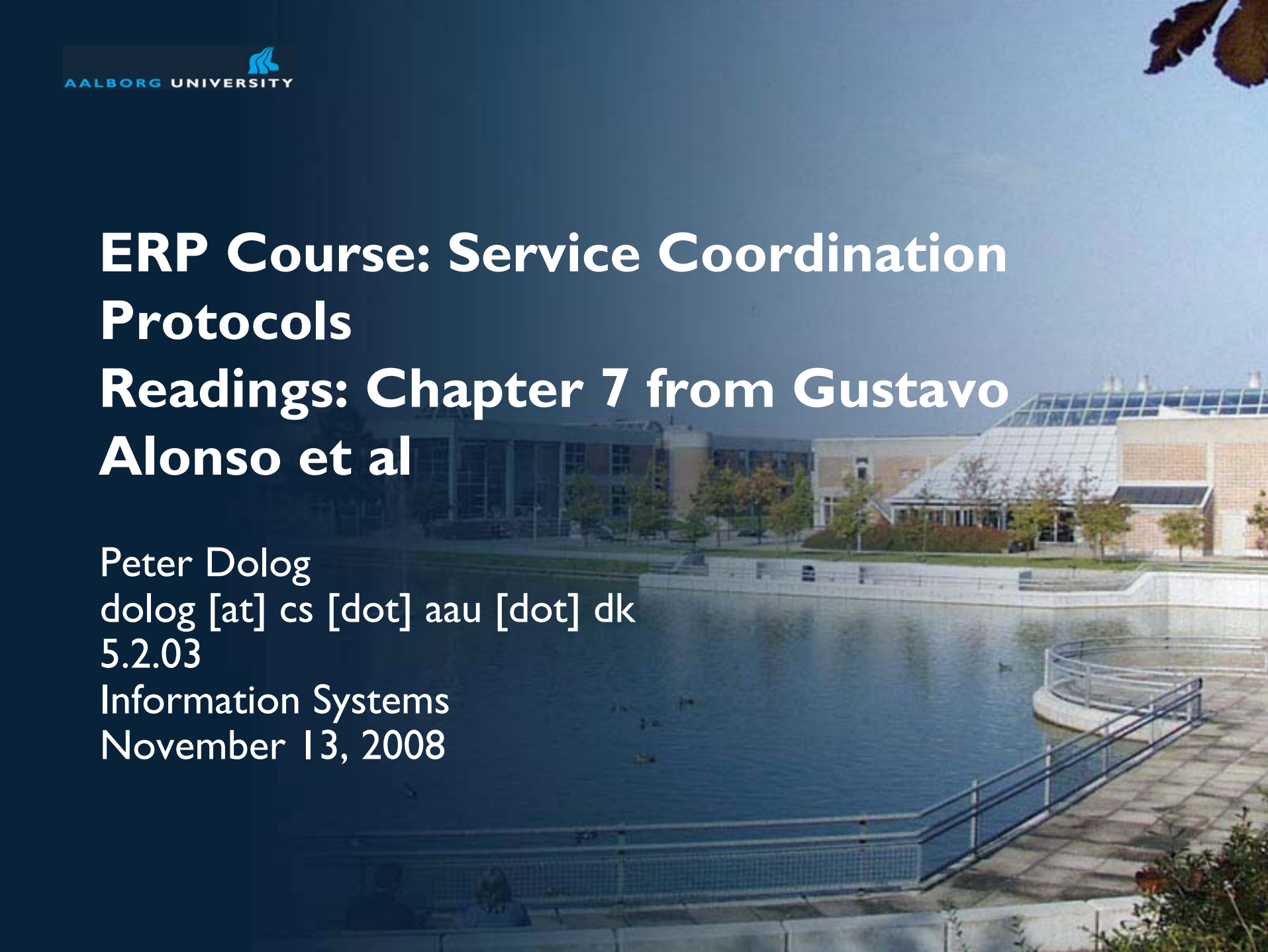

The interaction between clients and services is often formed by a set of operation invocations (i.e., it is a *conversation*).
A service provider may support some conversations while disallowing others.

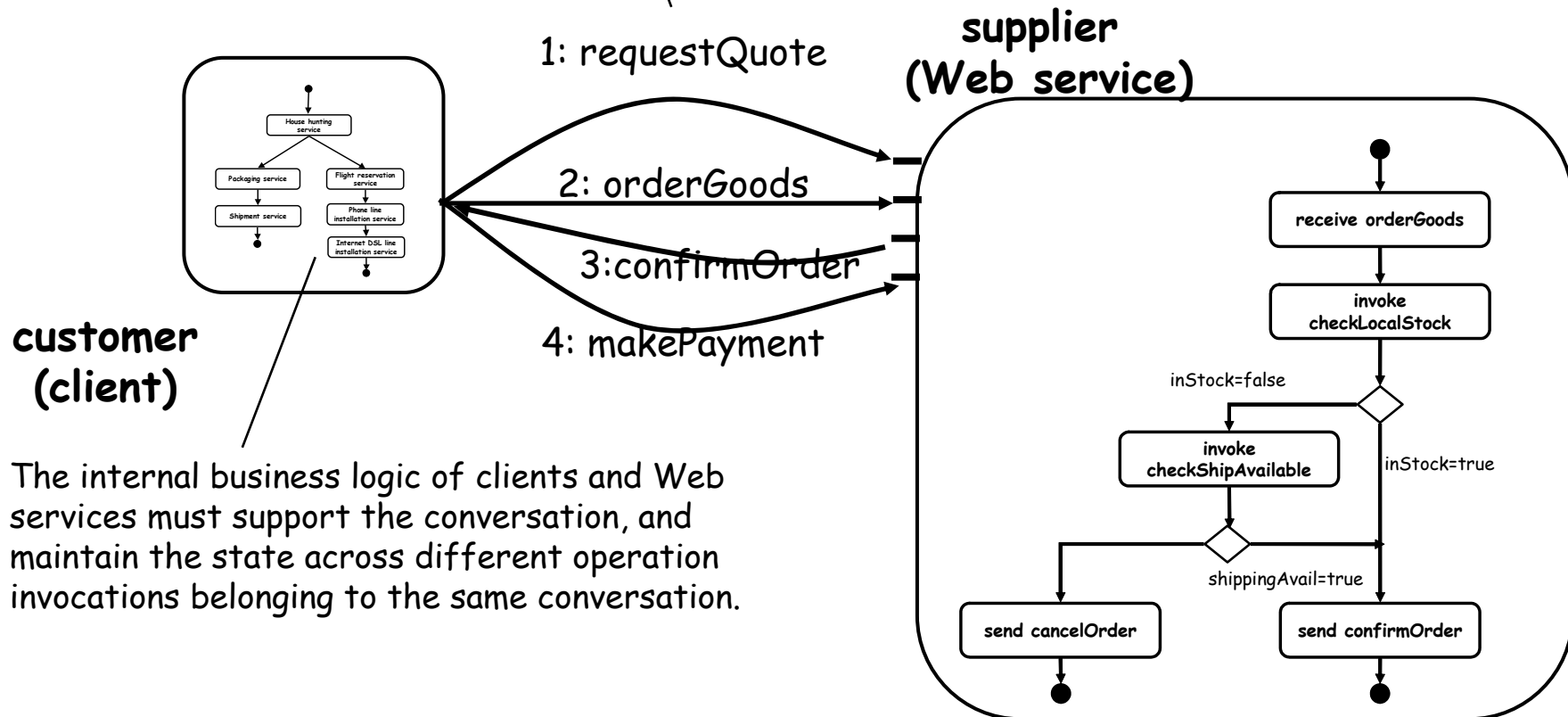

Valid States and Messages

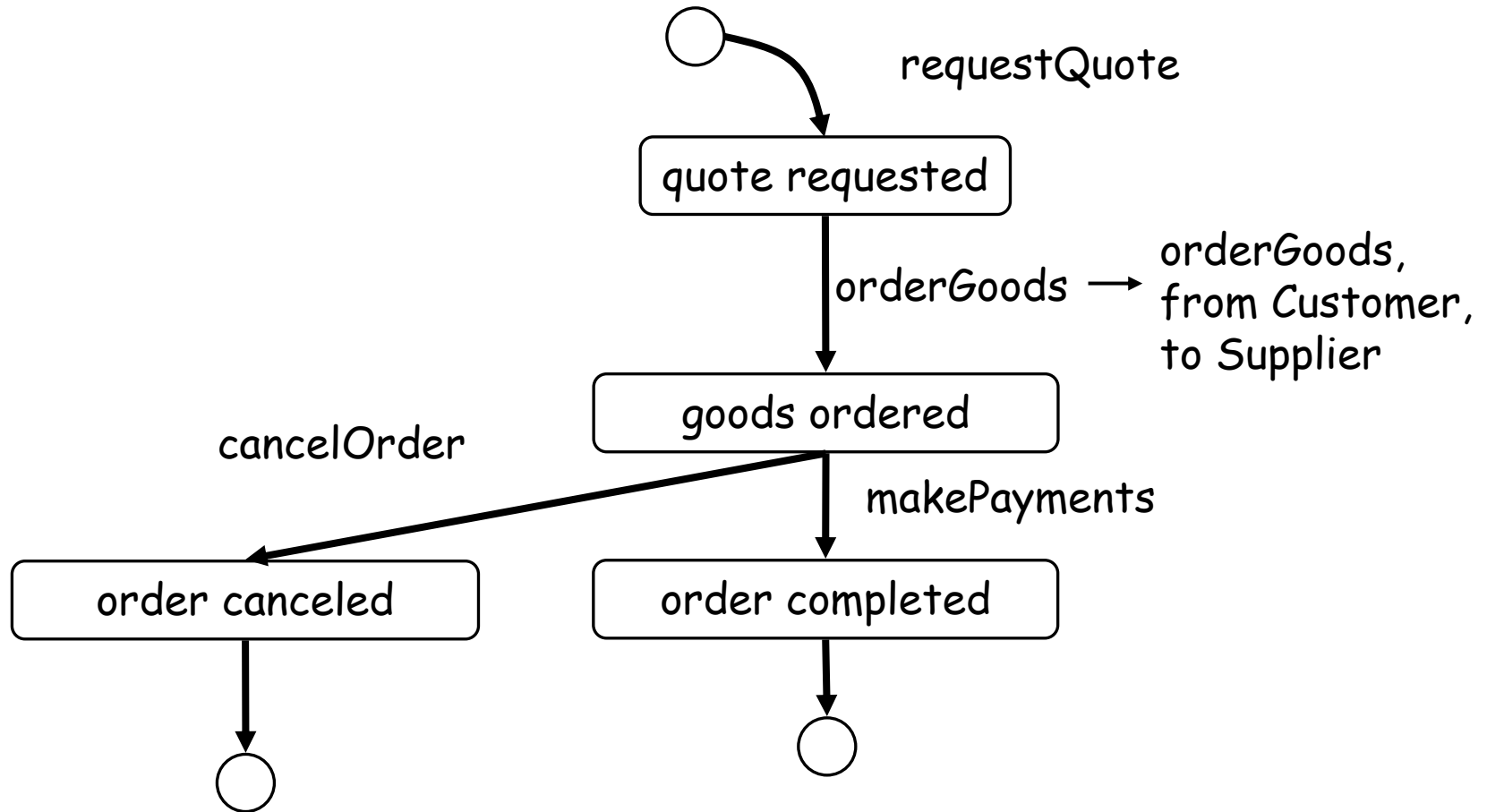

Various Roles and Conversation Participants

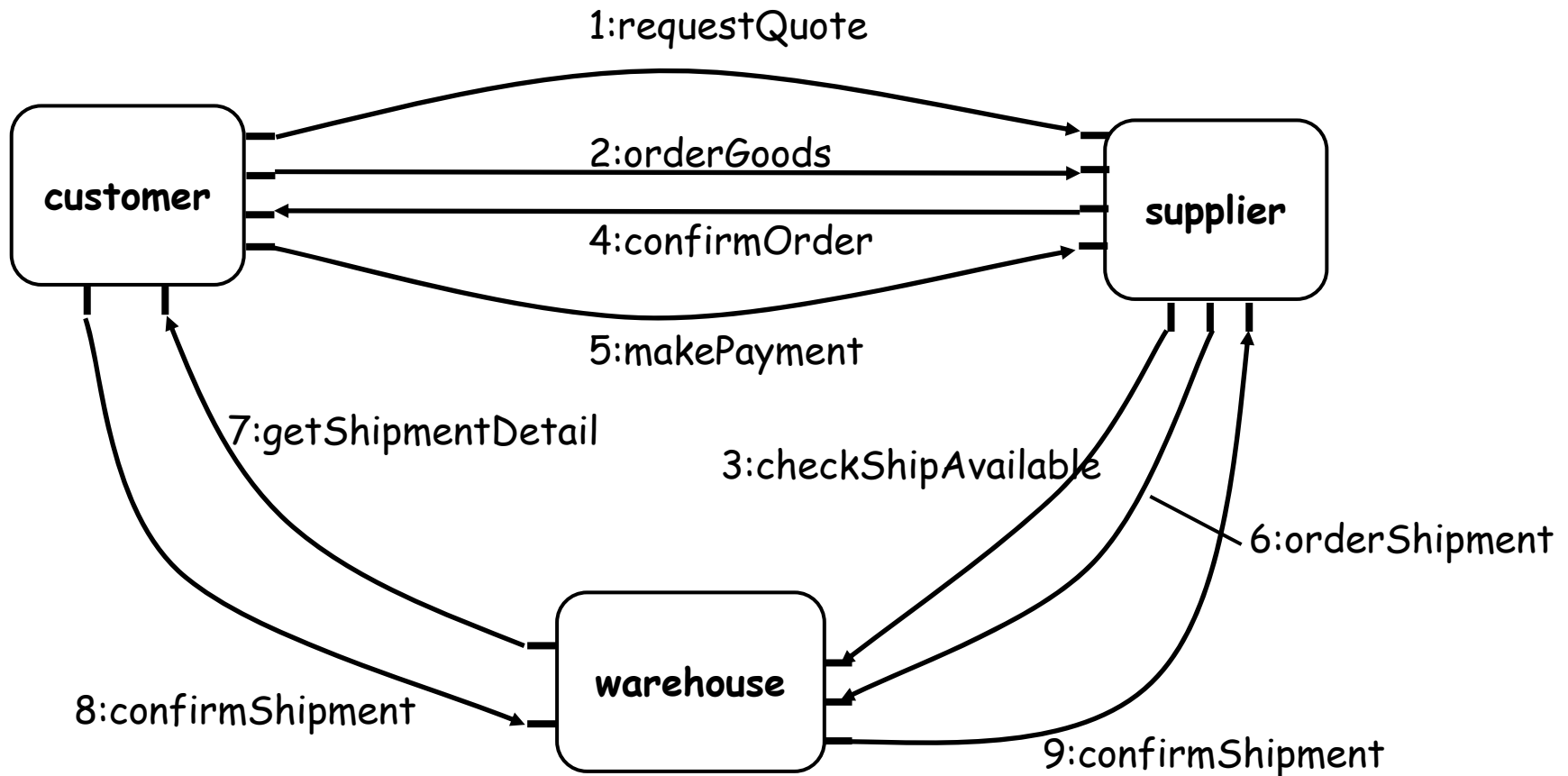

Interaction Modeling

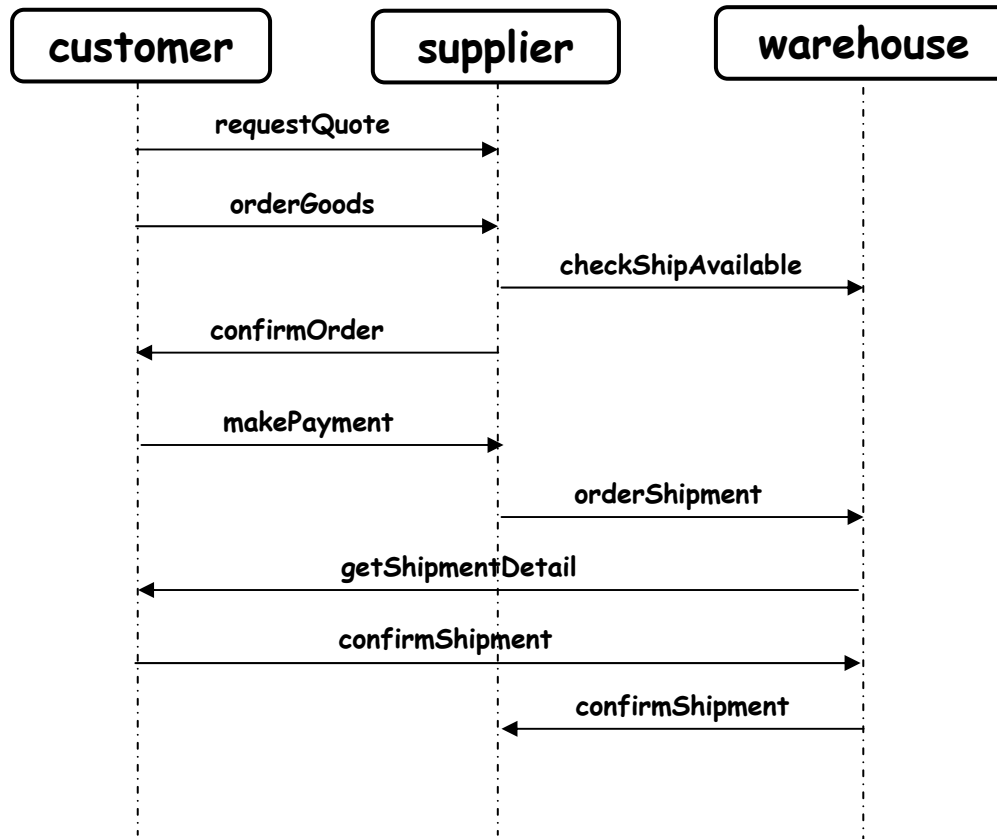

Activity Graphs

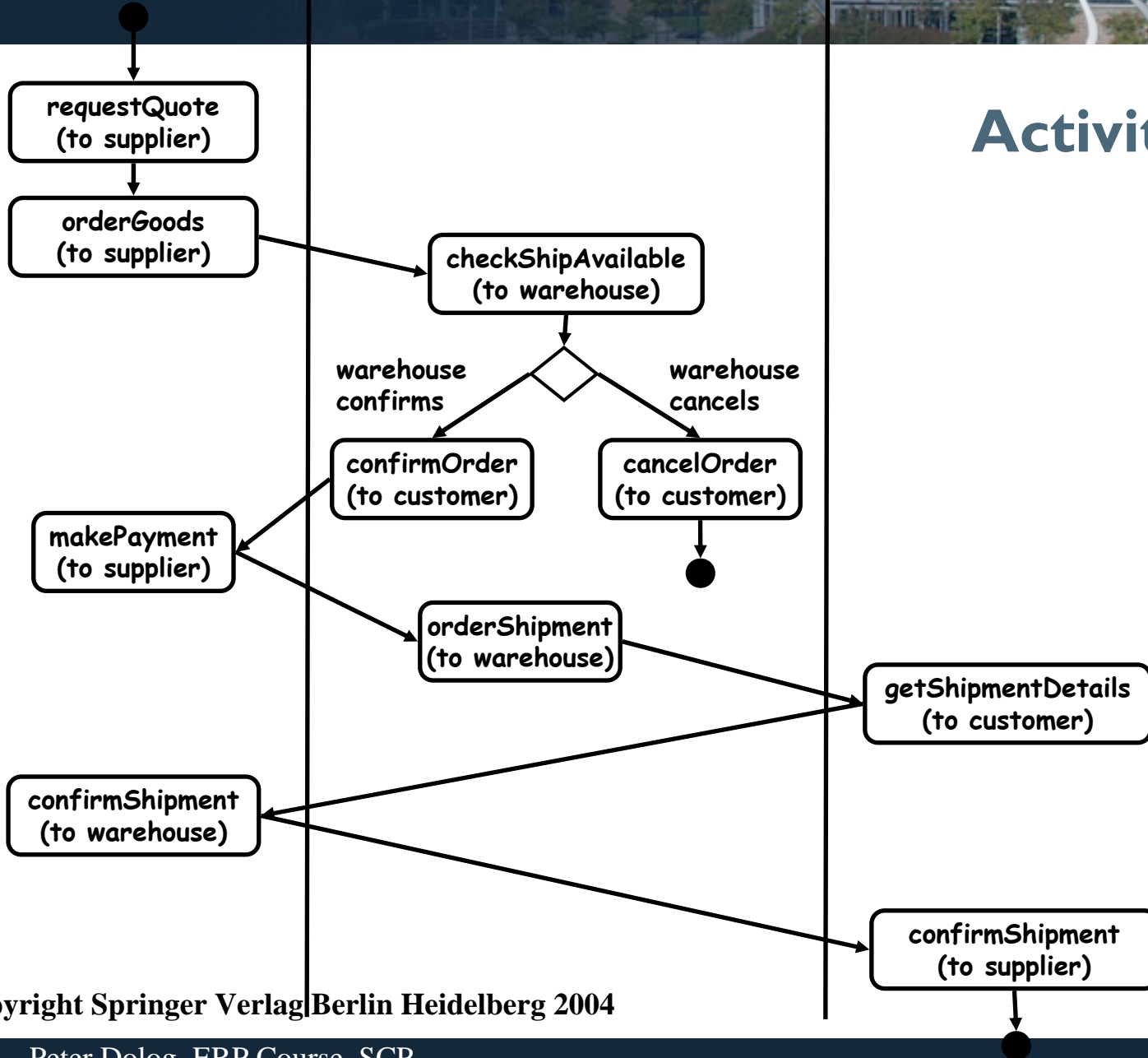

Views Based on Roles

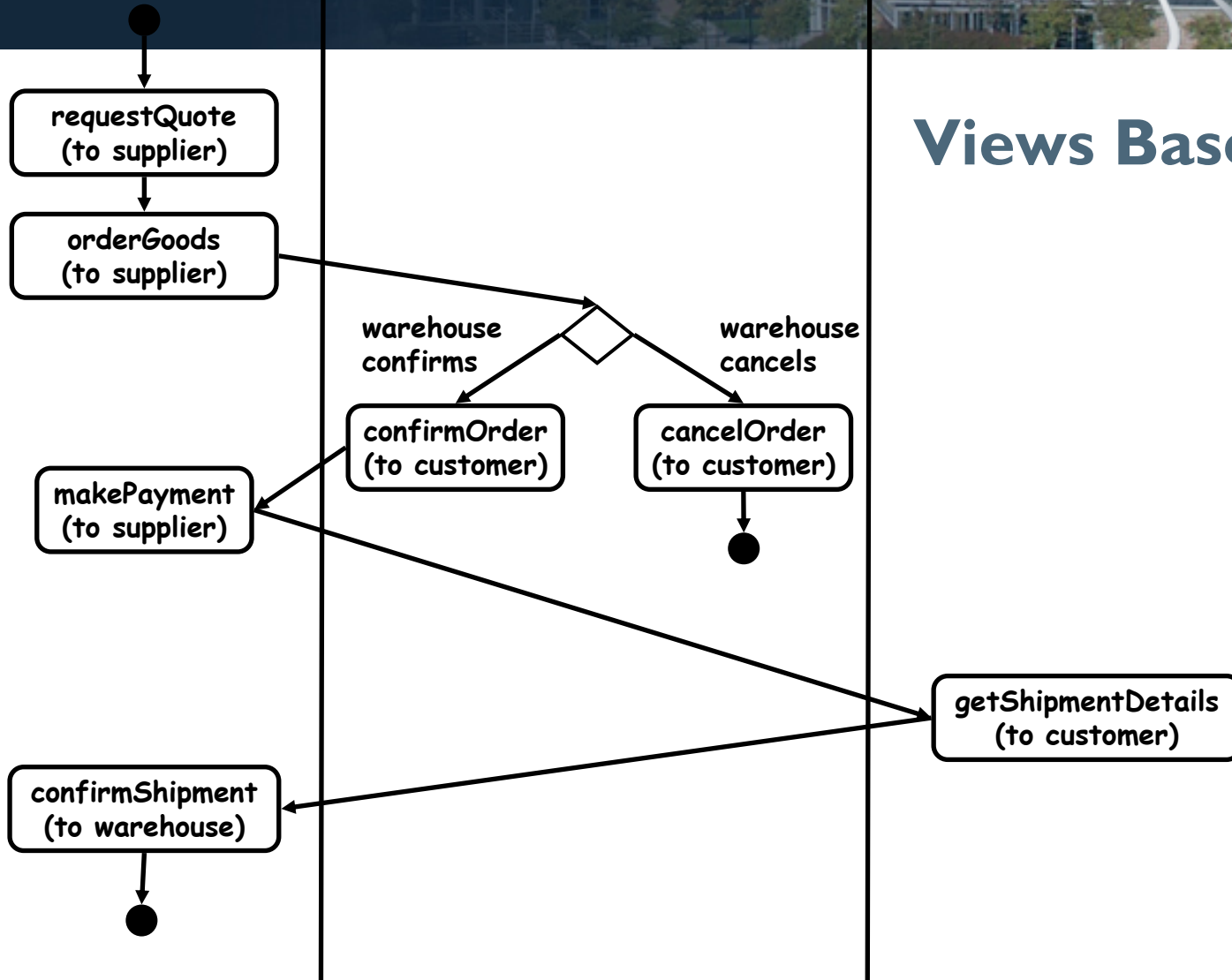

Horizontal vs. Vertical Protocols

service provider

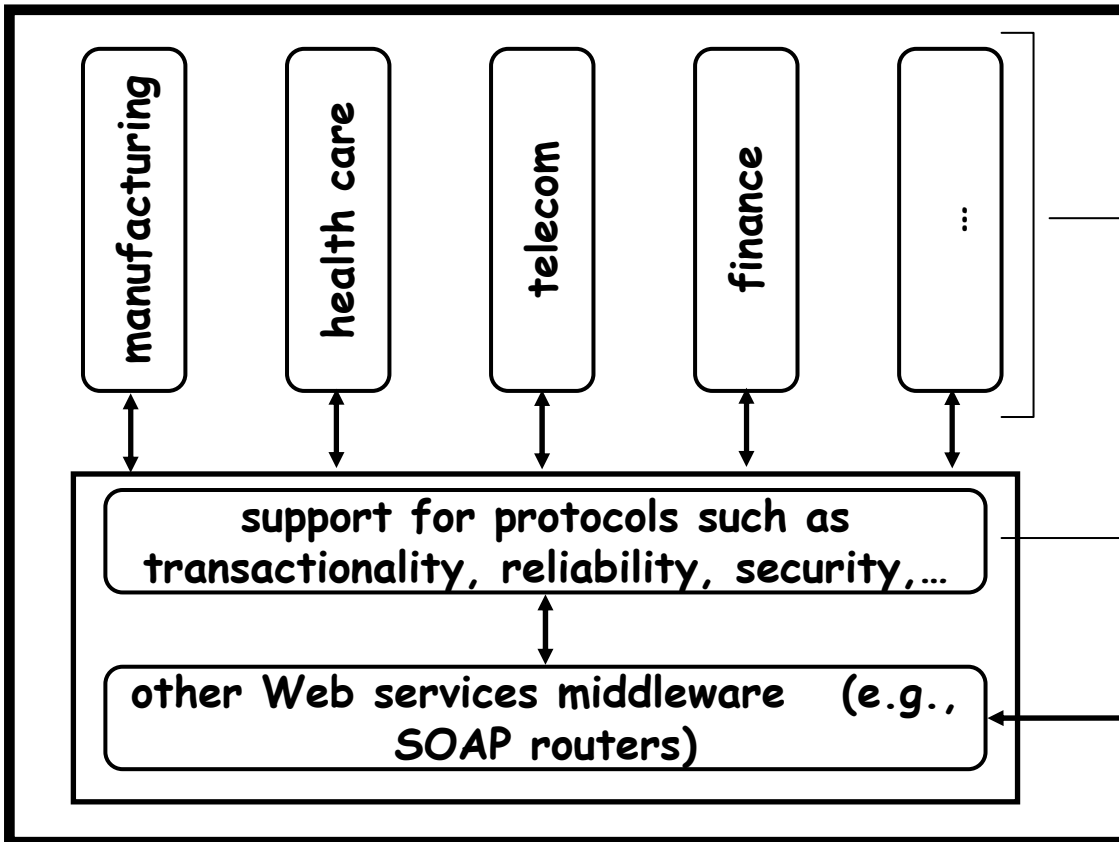

Web services executing vertical protocols. The main focus of standards such as RosettaNet, xCBL, and part of ebXML is to describe protocols at this level.

middleware for horizontal protocols provides properties and guarantees to the execution vertical protocols. Standards such as WS-Coordination, WS-Transaction, and part of ebXML fit here.

SOAP messages

Generic Conversation

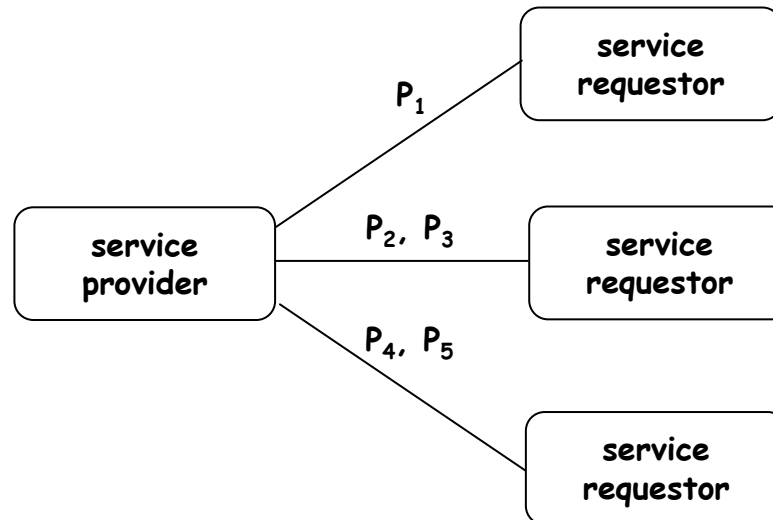

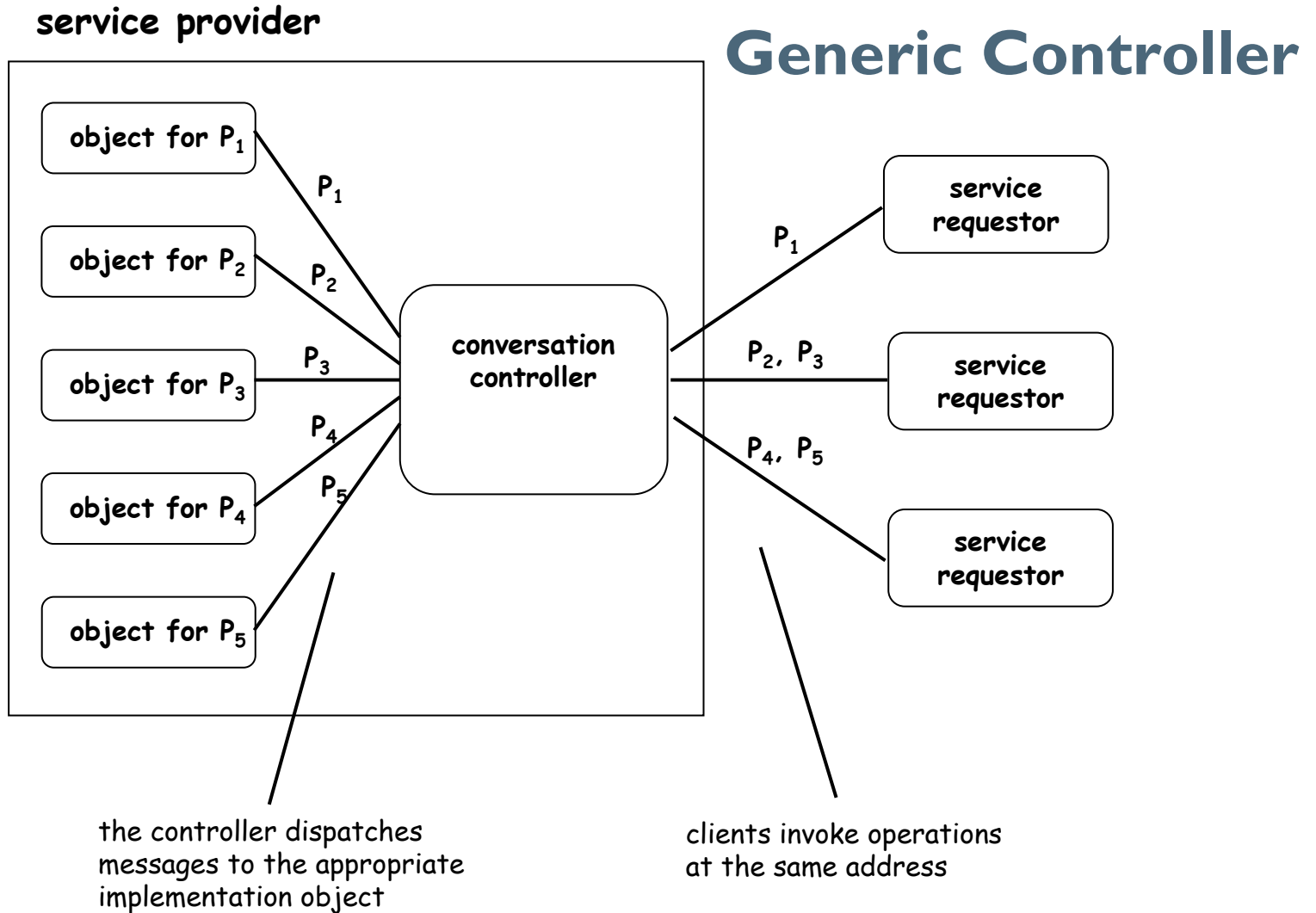

Conversation Ids in the Message Headers

service provider

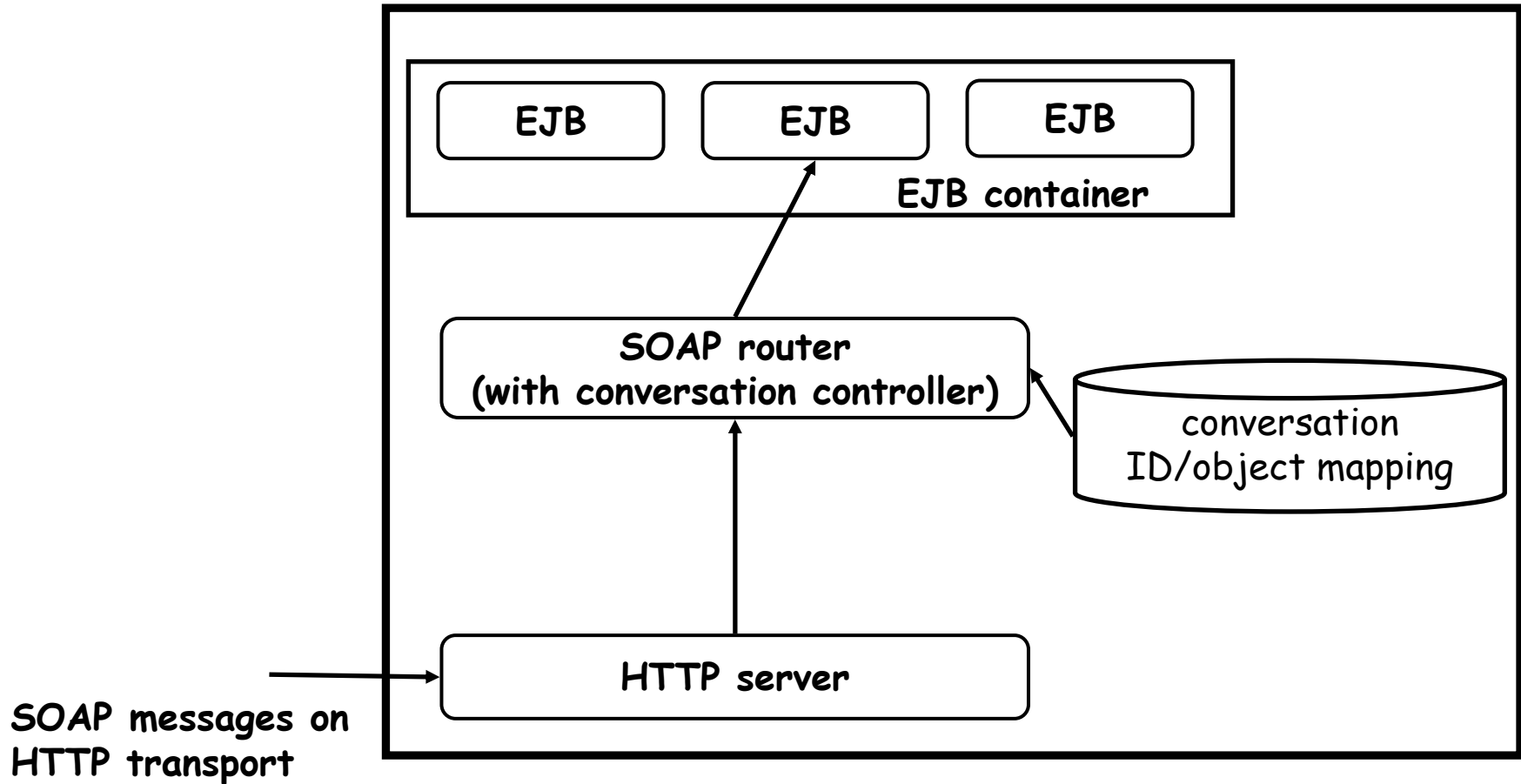

Horizontal and Vertical Protocol Coordination

service provider

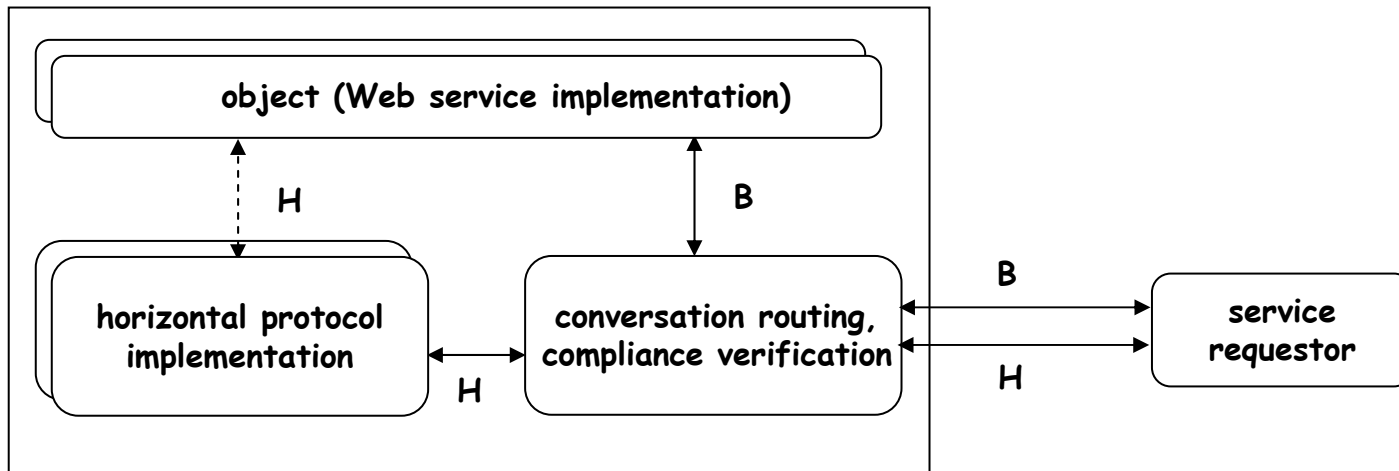

B: conversation compliant with a business protocol
H: conversation compliant with an horizontal protocol

Example

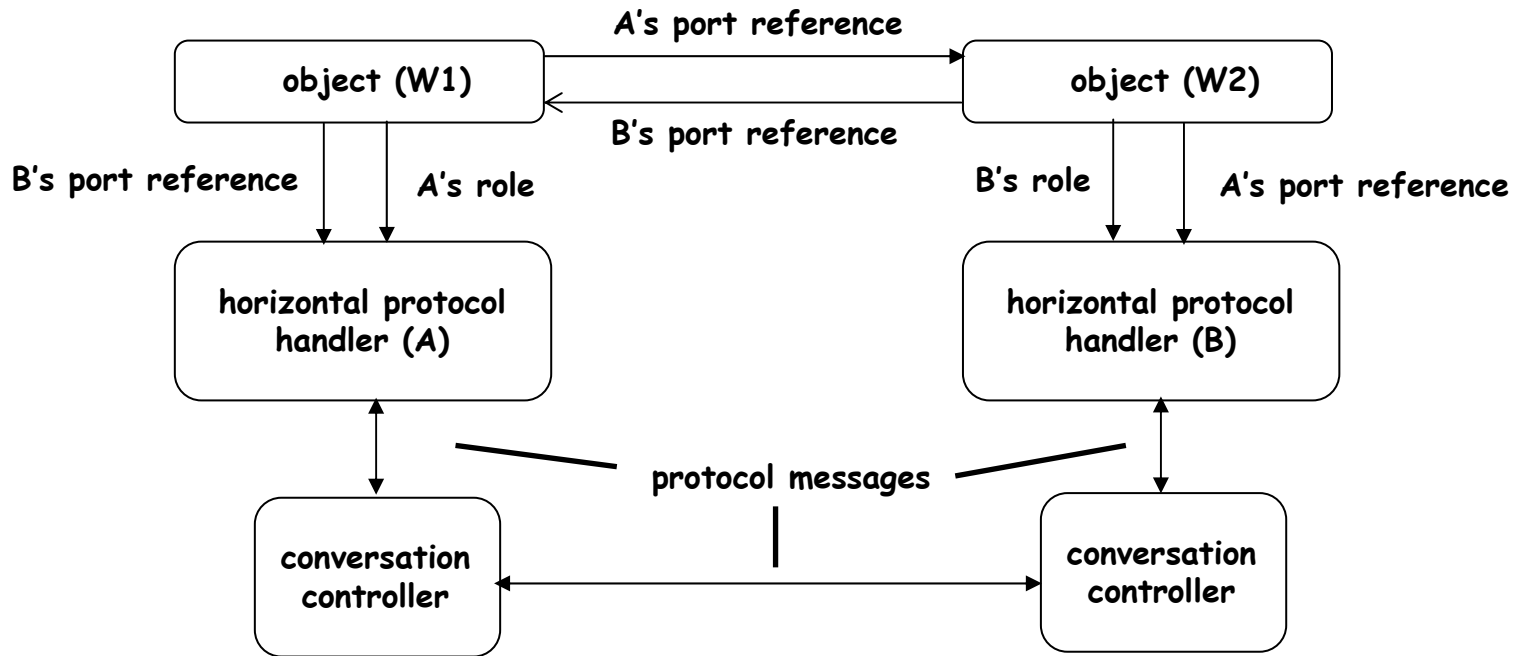

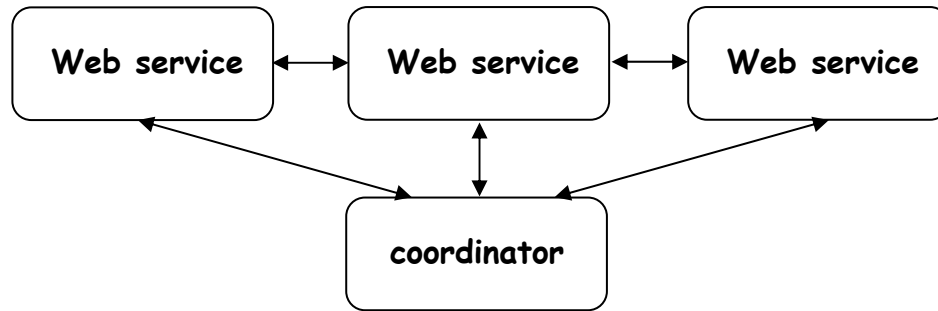

(a) central coordination

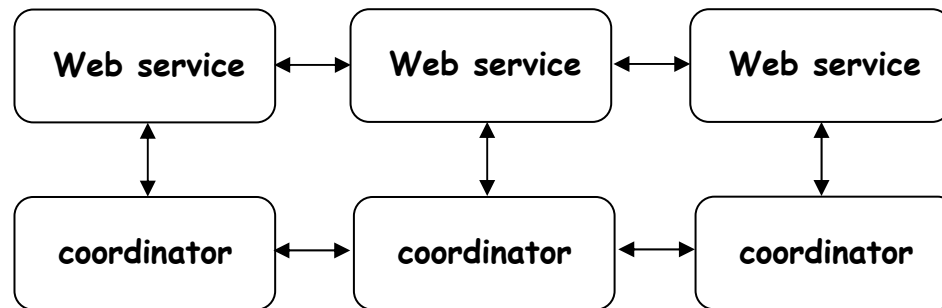

(b) distributed coordination

WS-Coordination – Activation

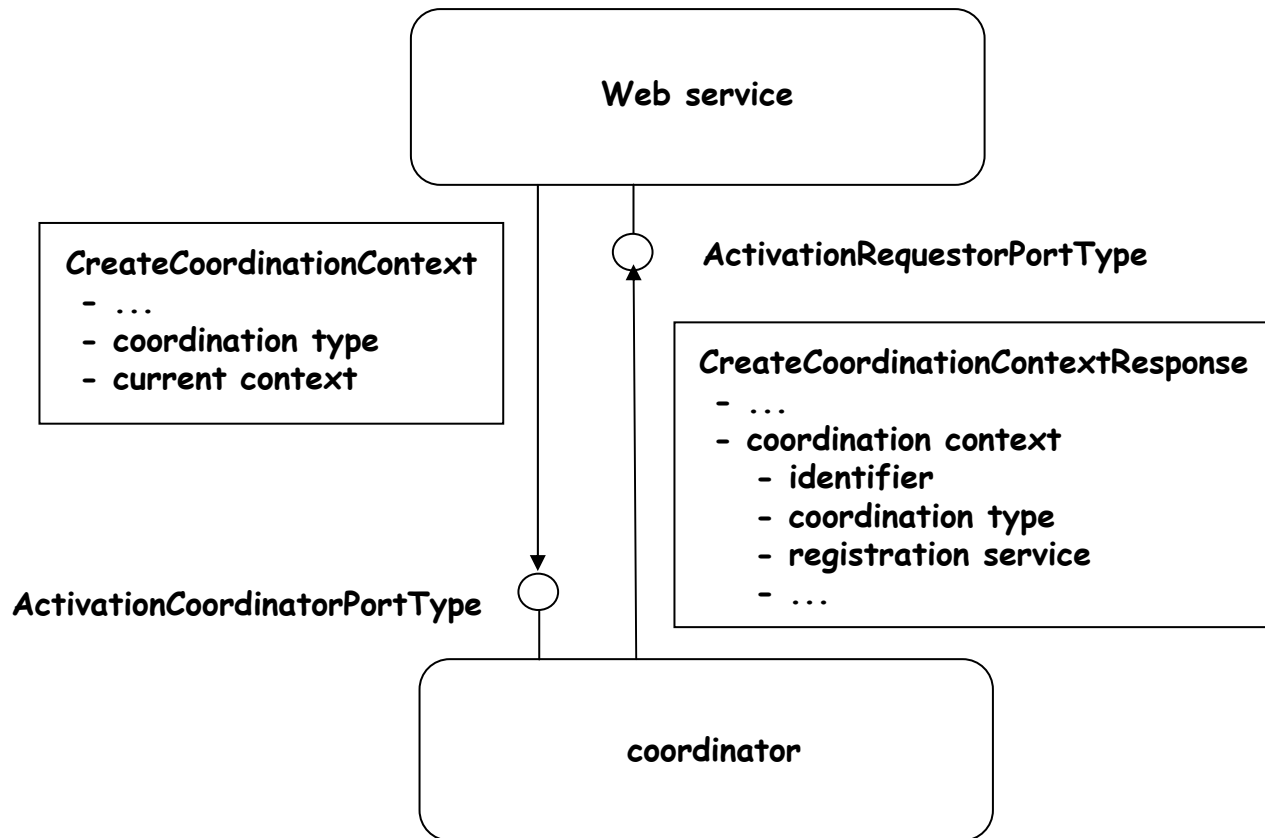

Participant Registration

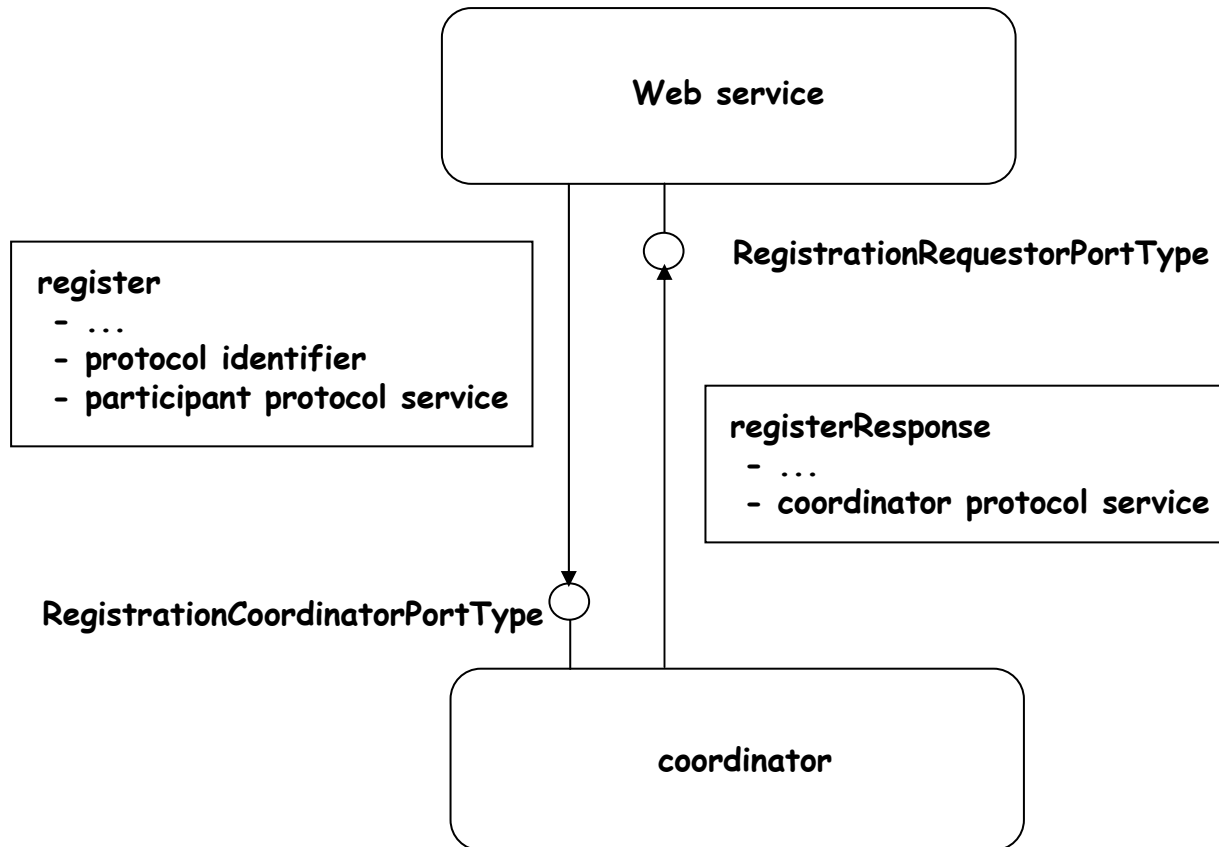

Protocol Specific Message Exchange

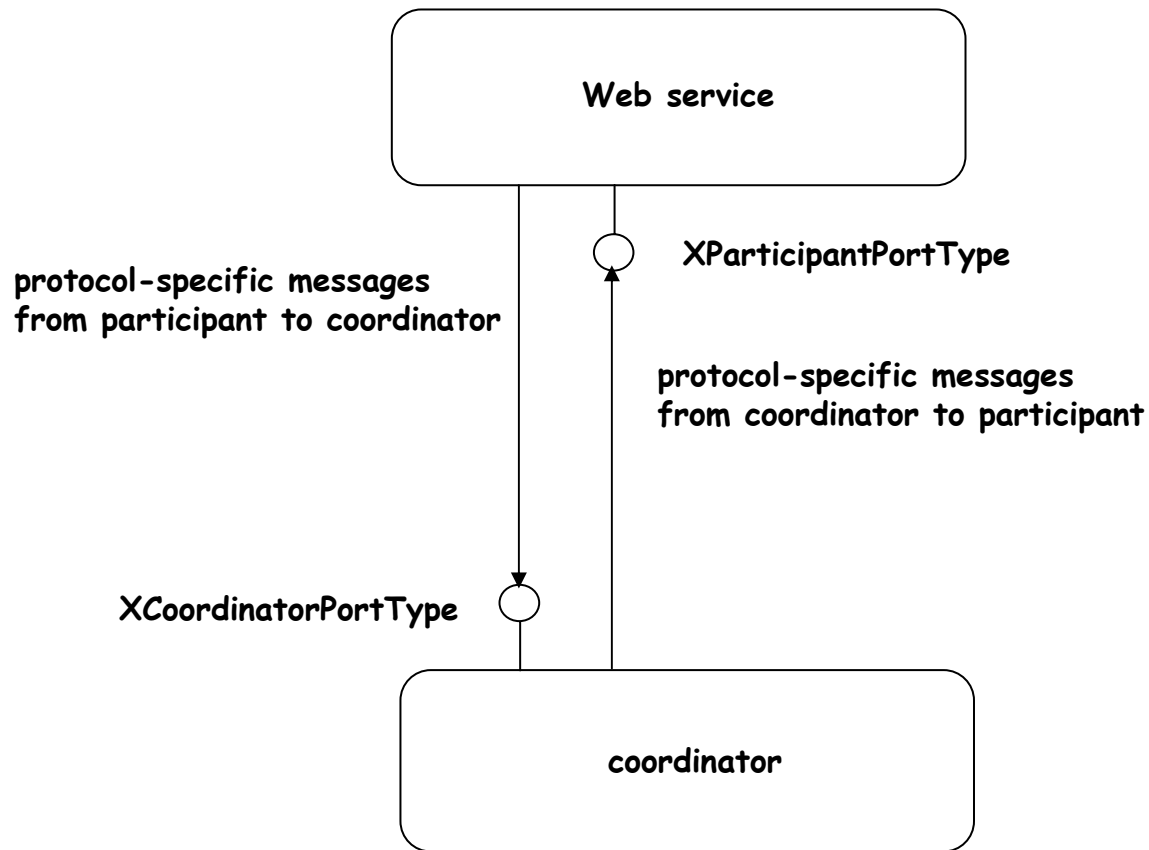

Protocol Specific Messages/ WS Transaction – BA

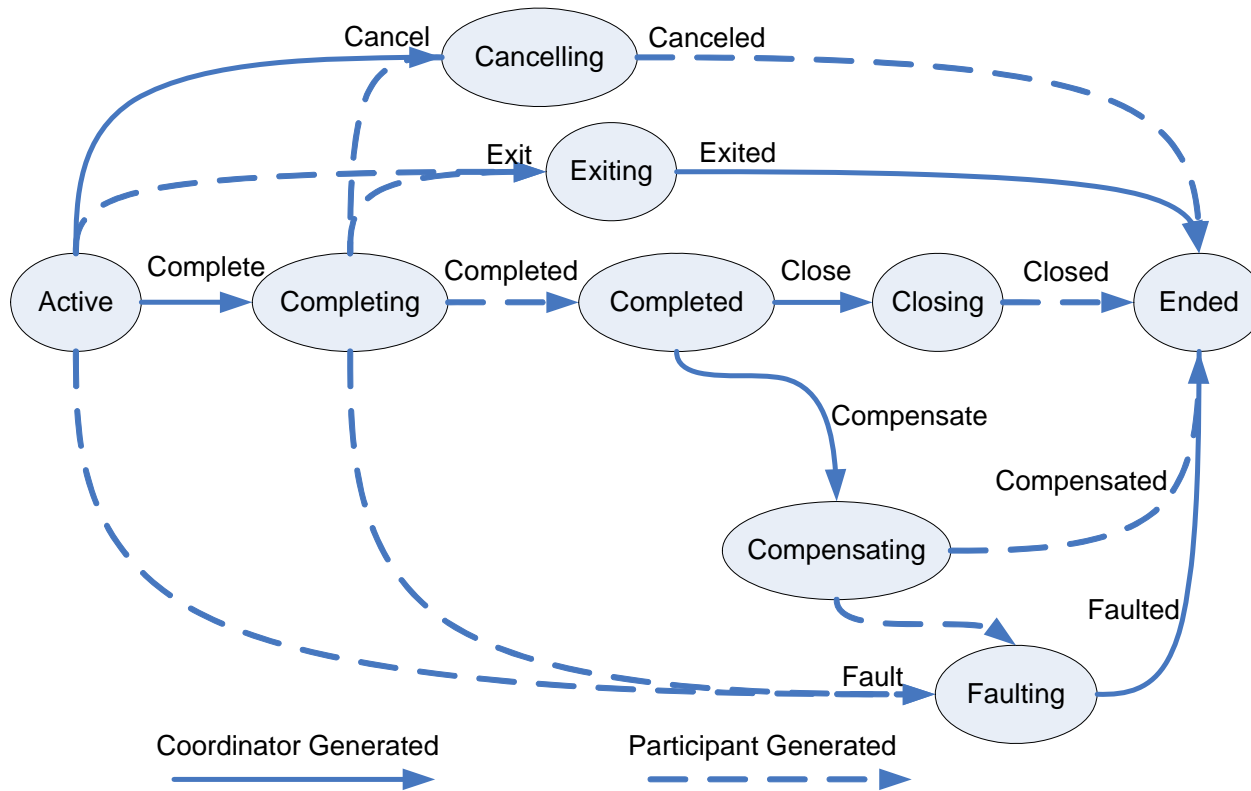

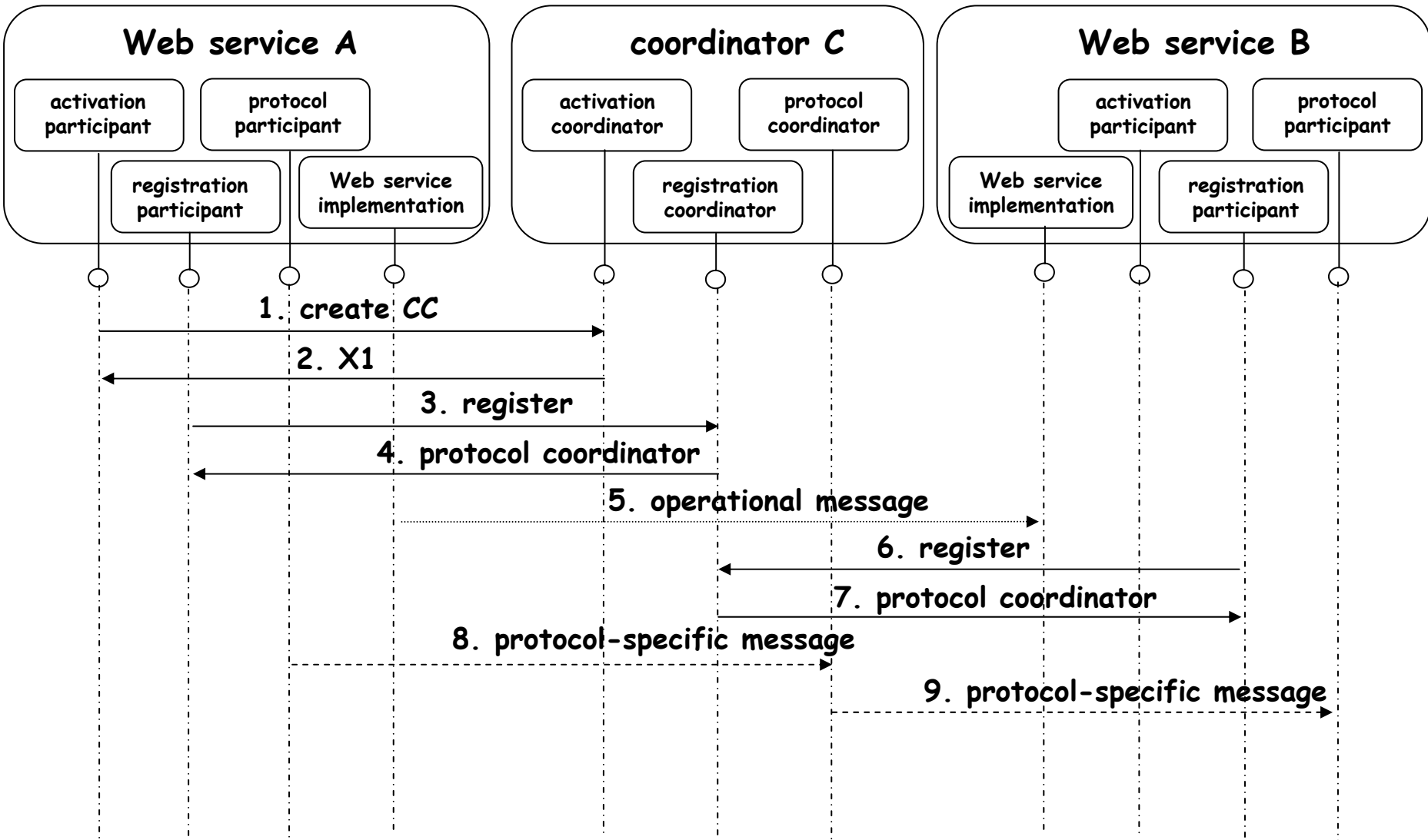

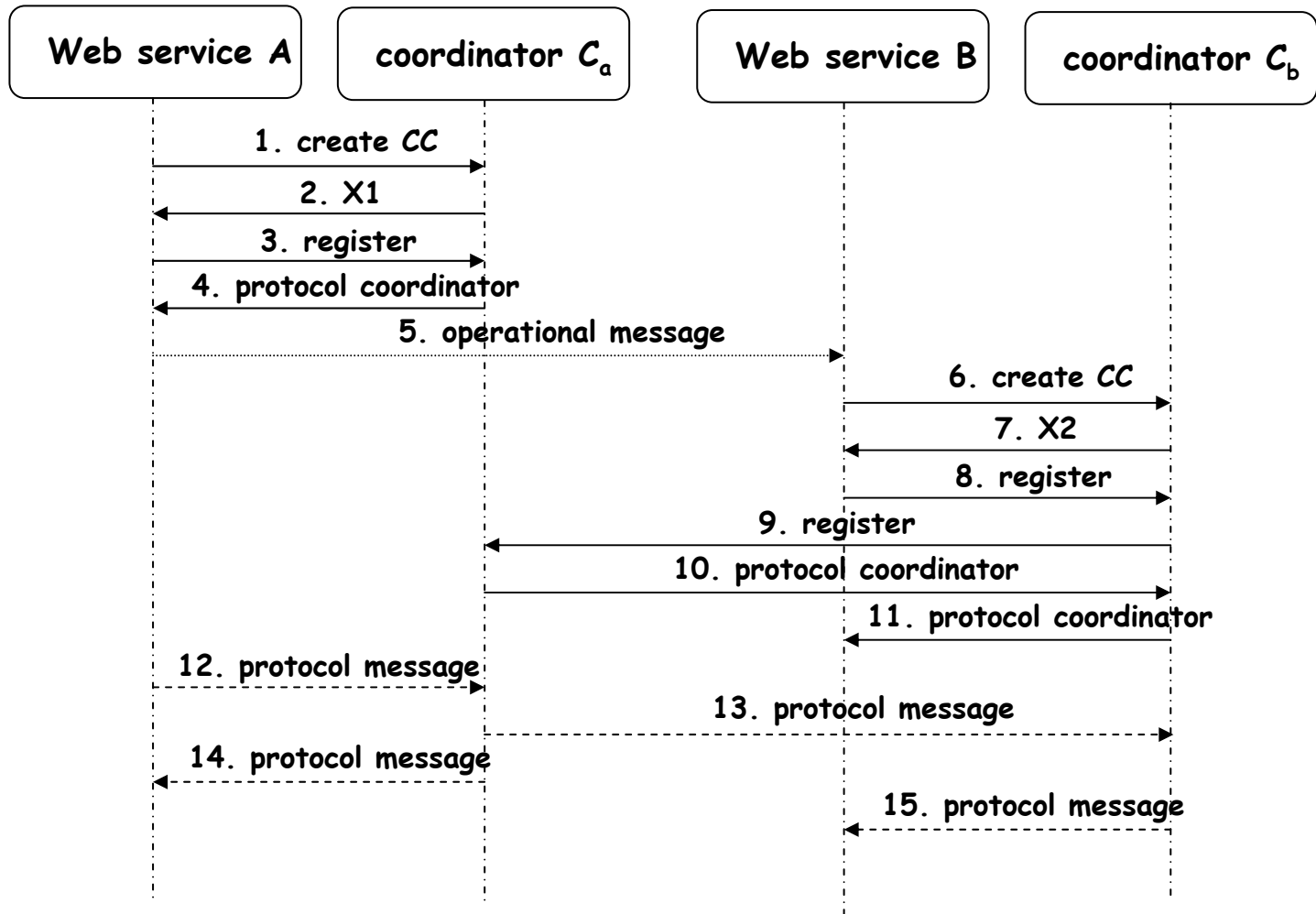

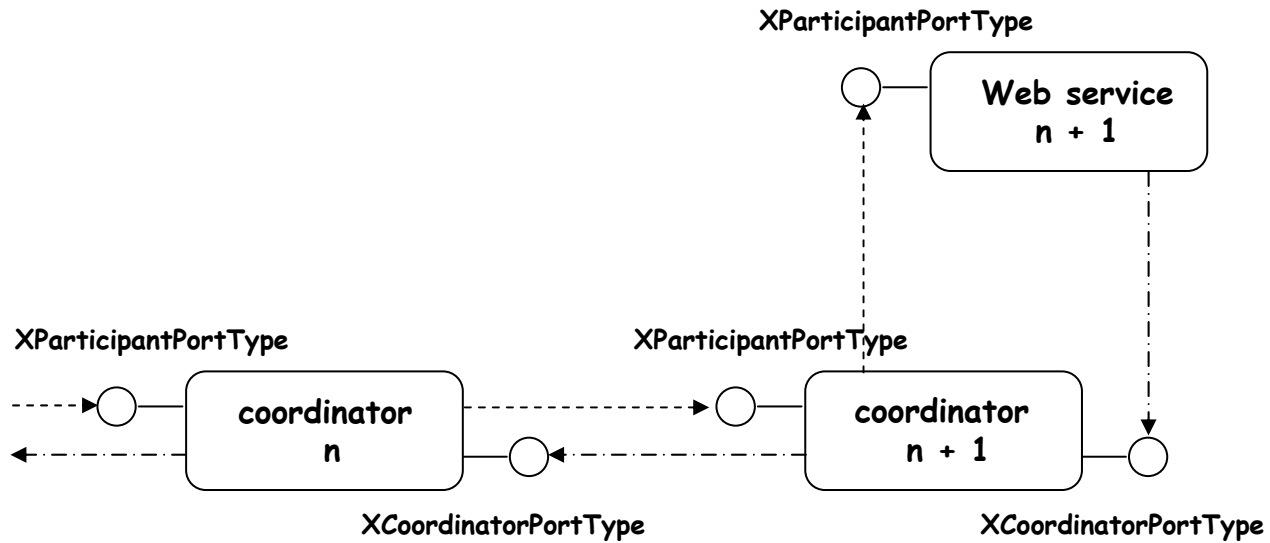

WS-Coordination interfaces

ActivationCoordinatorPortType

RegistrationCoordinatorPortType

WS-Transaction interfaces

CompletionParticipantPortType

CompletionCoordinatorPortType

CompletionWithAckParticipantPortType

CompletionWithAckCoordinatorPortType

PhaseZeroParticipantPortType

PhaseZeroCoordinatorPortType

2PCParticipantPortType

2PCCoordinatorPortType

OutcomeNotificationParticipantPortType

OutcomeNotificationCoordinatorPortType

atomic transaction coordinator

RegistrationParticipantPortType

WS-Transaction interfaces needed for chaining

WS-Coordination interfaces needed for chaining