

# Virtual Memory: Concepts

Lecture 10-11, May 5-12<sup>th</sup> 2011.

Alexandre David

**Credits to Randy Bryant & Dave O'Hallaron  
from Carnegie Mellon**

# Today

- **Address spaces**
- VM as a tool for caching
- VM as a tool for memory management
- VM as a tool for memory protection
- Address translation

# A System Using Physical Addressing

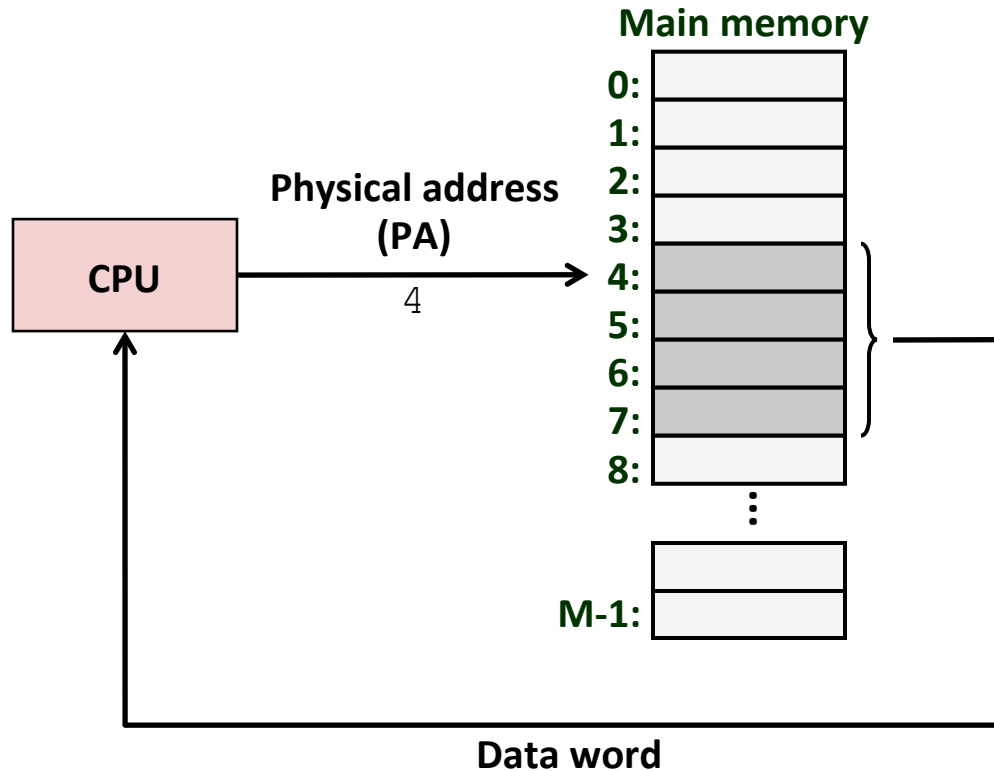

- Used in “simple” systems like embedded microcontrollers in devices like cars, elevators, and digital picture frames

# A System Using Virtual Addressing

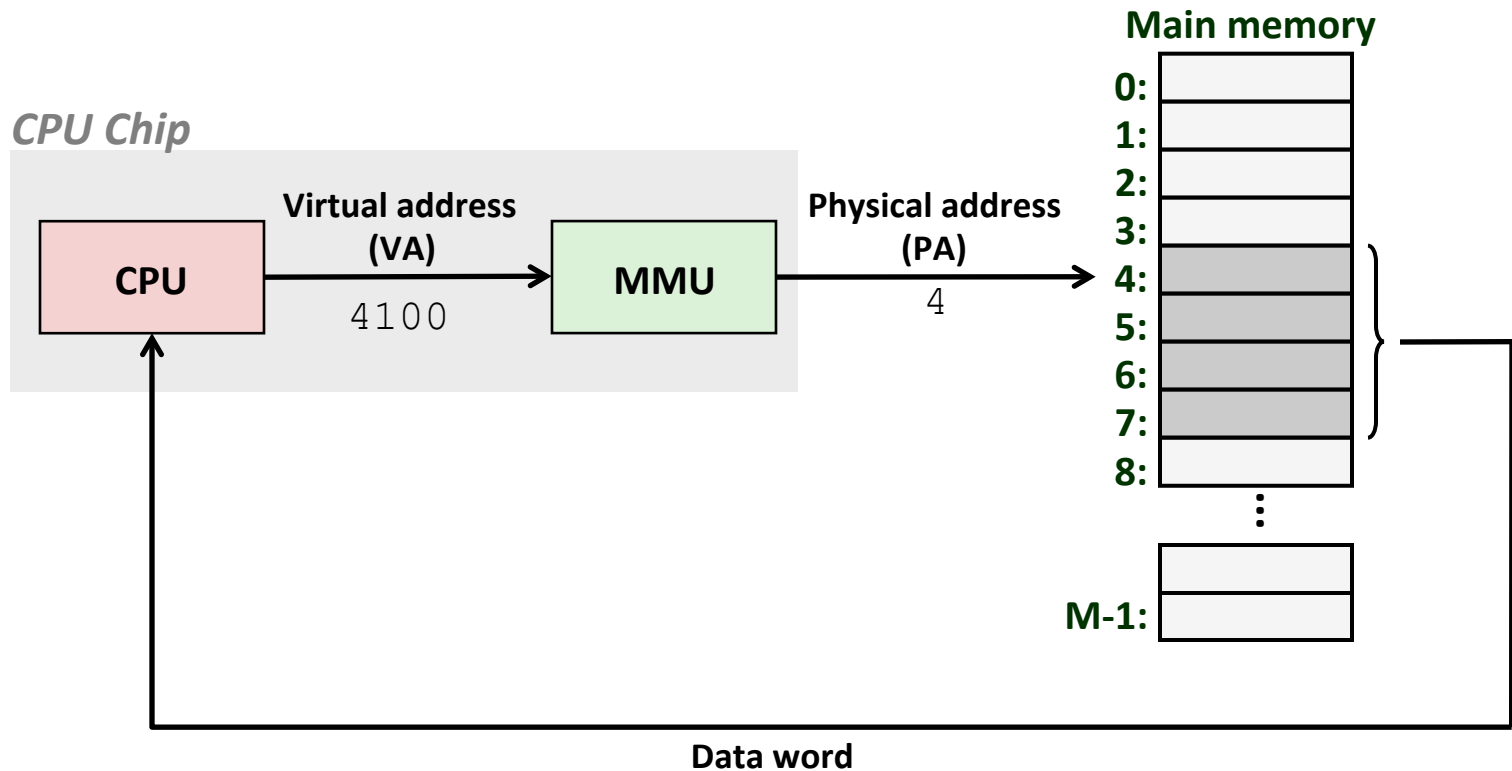

- Used in all modern servers, desktops, and laptops
- One of the great ideas in computer science

# Address Spaces

- **Linear address space:** Ordered set of contiguous non-negative integer addresses:

$\{0, 1, 2, 3 \dots \}$

- **Virtual address space:** Set of  $N = 2^n$  virtual addresses

$\{0, 1, 2, 3, \dots, N-1\}$

- **Physical address space:** Set of  $M = 2^m$  physical addresses

$\{0, 1, 2, 3, \dots, M-1\}$

- **Clean distinction between data (bytes) and their attributes (addresses)**
- **Each object can now have multiple addresses**
- **Every byte in main memory:  
one physical address, one (or more) virtual addresses**

# Why Virtual Memory (VM)?

- **Uses main memory efficiently**
  - Use DRAM as a cache for the parts of a virtual address space
- **Simplifies memory management**
  - Each process gets the same uniform linear address space
  - **Abstraction**
- **Isolates address spaces**
  - One process can't interfere with another's memory
  - User program cannot access privileged kernel information
  - **Protection**

# Today

- Address spaces
- **VM as a tool for caching**
- VM as a tool for memory management
- VM as a tool for memory protection
- Address translation

# VM as a Tool for Caching

- **Virtual memory** is an array of  $N$  contiguous bytes stored on disk.
- The contents of the array on disk are cached in **physical memory (DRAM cache)**
  - These cache blocks are called *pages* (size is  $P = 2^p$  bytes)

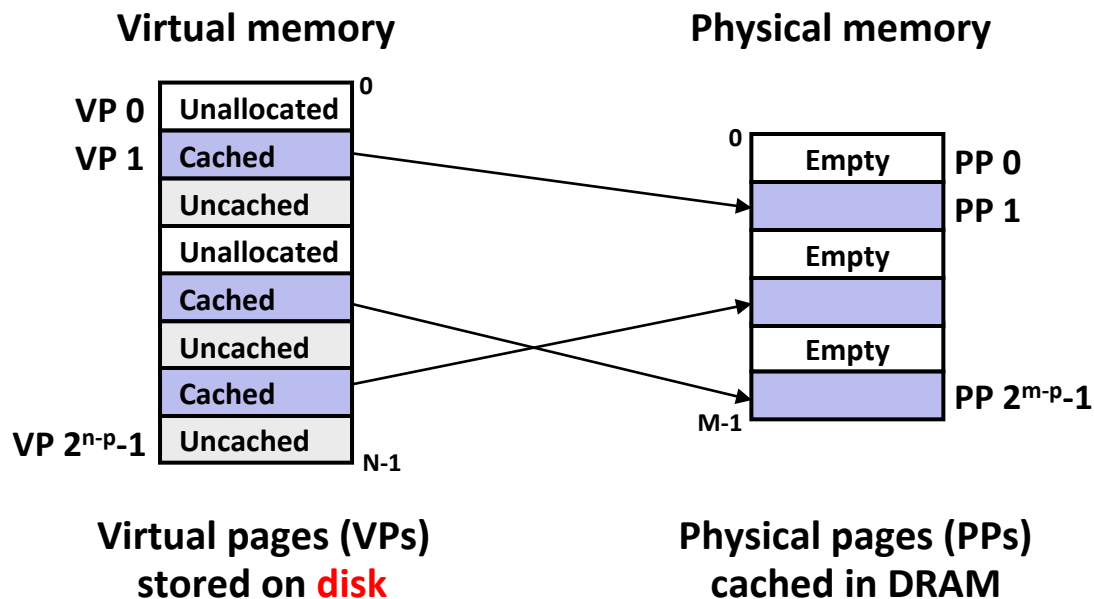



# DRAM Cache Organization

- **DRAM cache organization driven by the enormous miss penalty**
  - DRAM is about **10x** slower than SRAM
  - Disk is about **10,000x** slower than DRAM
- **Consequences**
  - Large page (block) size: typically 4-8 KB, sometimes 4 MB
  - Fully associative
    - Any VP can be placed in any PP
    - Requires a “large” mapping function – different from CPU caches
  - Highly sophisticated, expensive replacement algorithms
    - Too complicated and open-ended to be implemented in hardware
  - Write-back rather than write-through

# Page Tables

- A **page table** is an array of page table entries (PTEs) that maps virtual pages to physical pages.
  - Per-process kernel data structure in DRAM

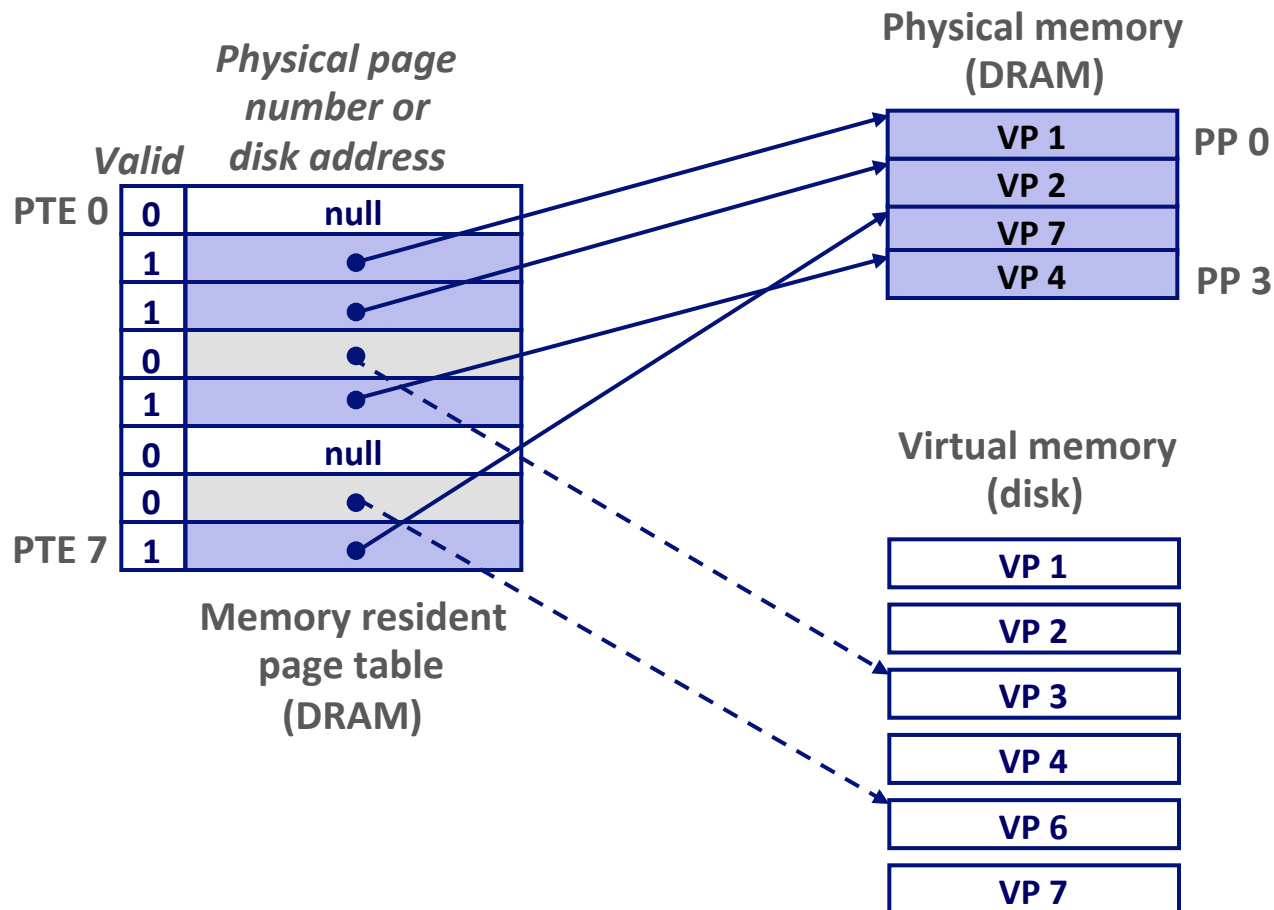

# Page Hit

- **Page hit:** reference to VM word that is in physical memory (DRAM cache hit)

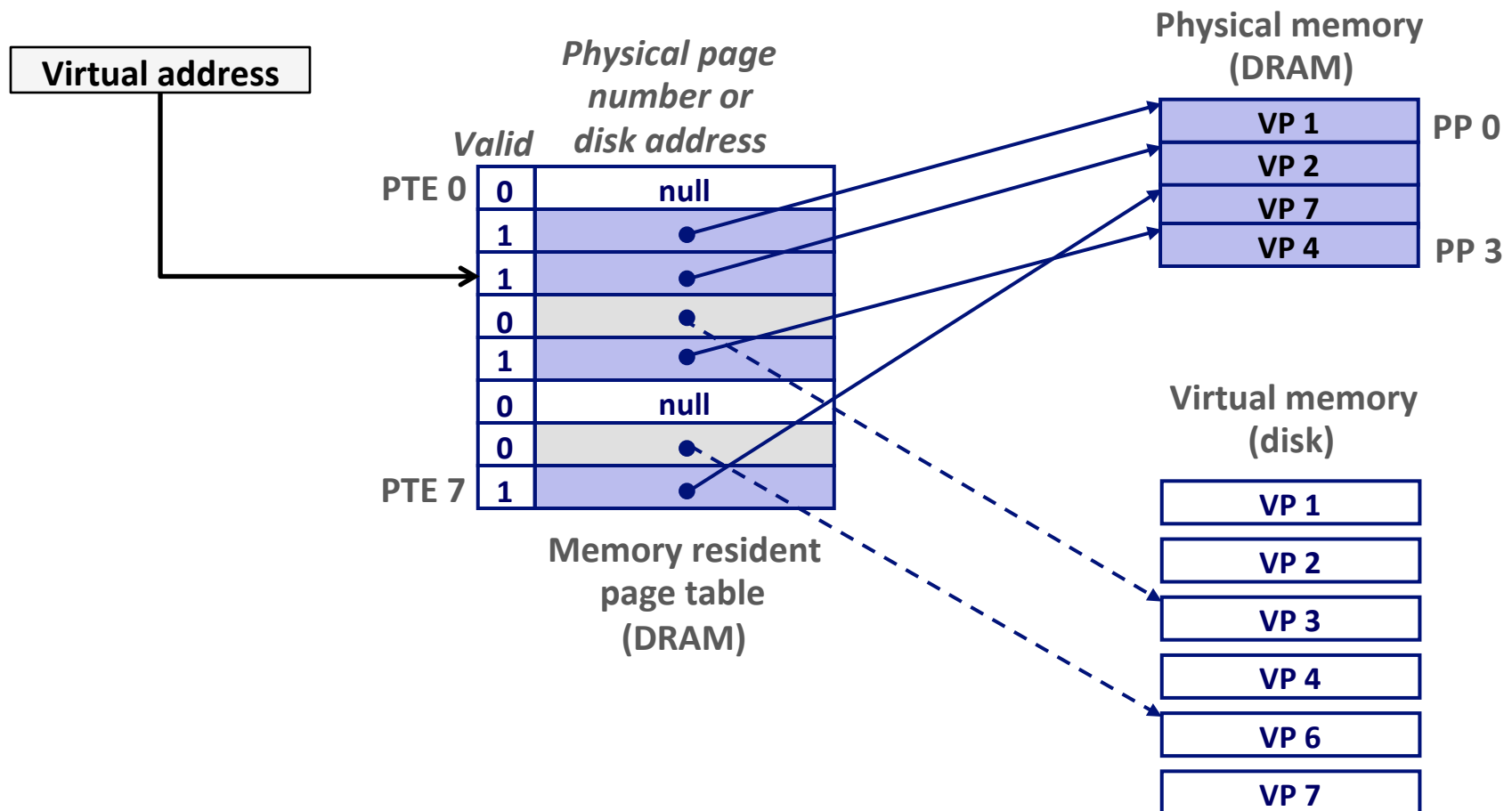

# Page Fault

- **Page fault:** reference to VM word that is not in physical memory (DRAM cache miss)

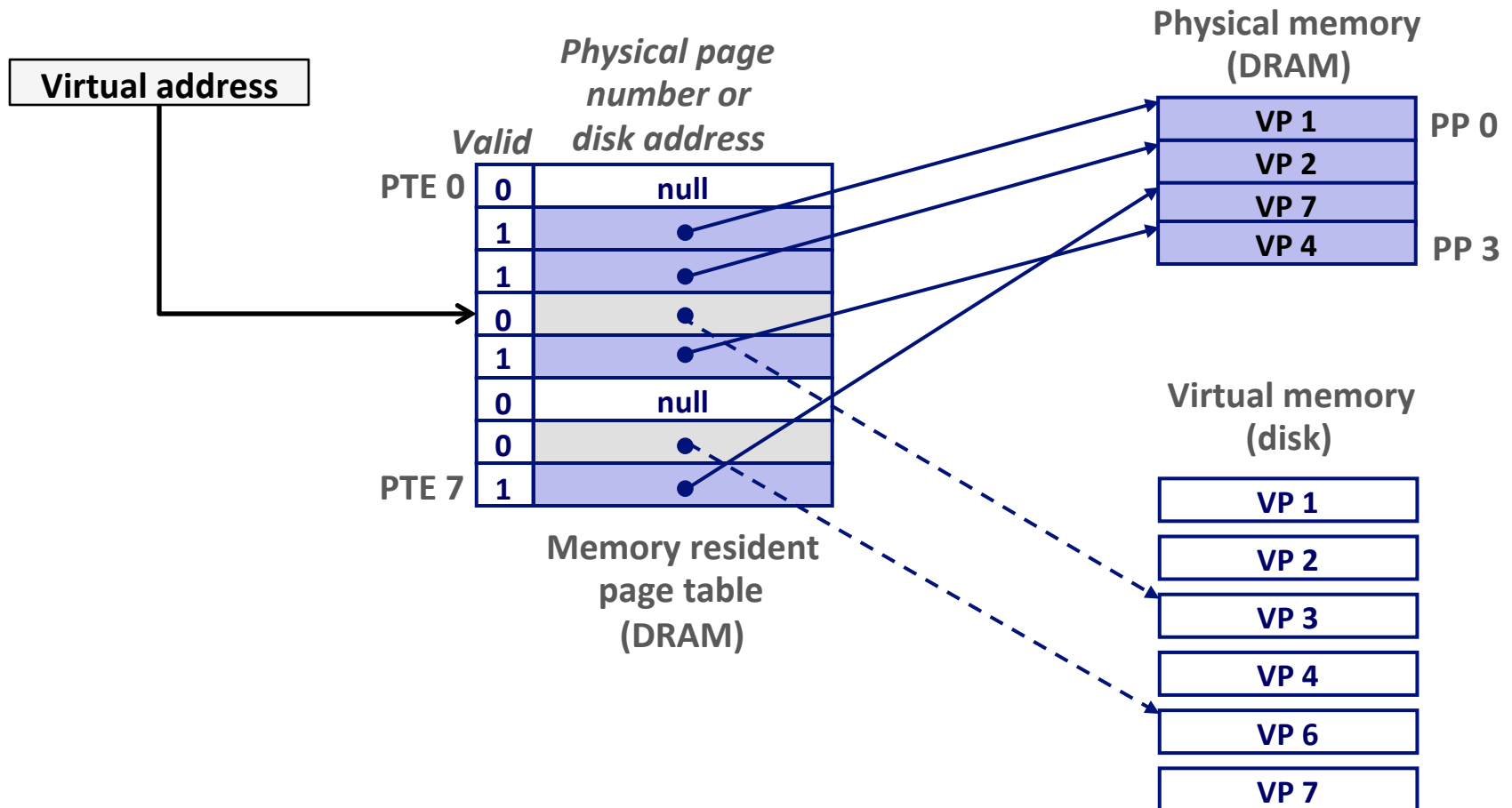

# Handling Page Fault

- Page miss causes page fault (an exception)

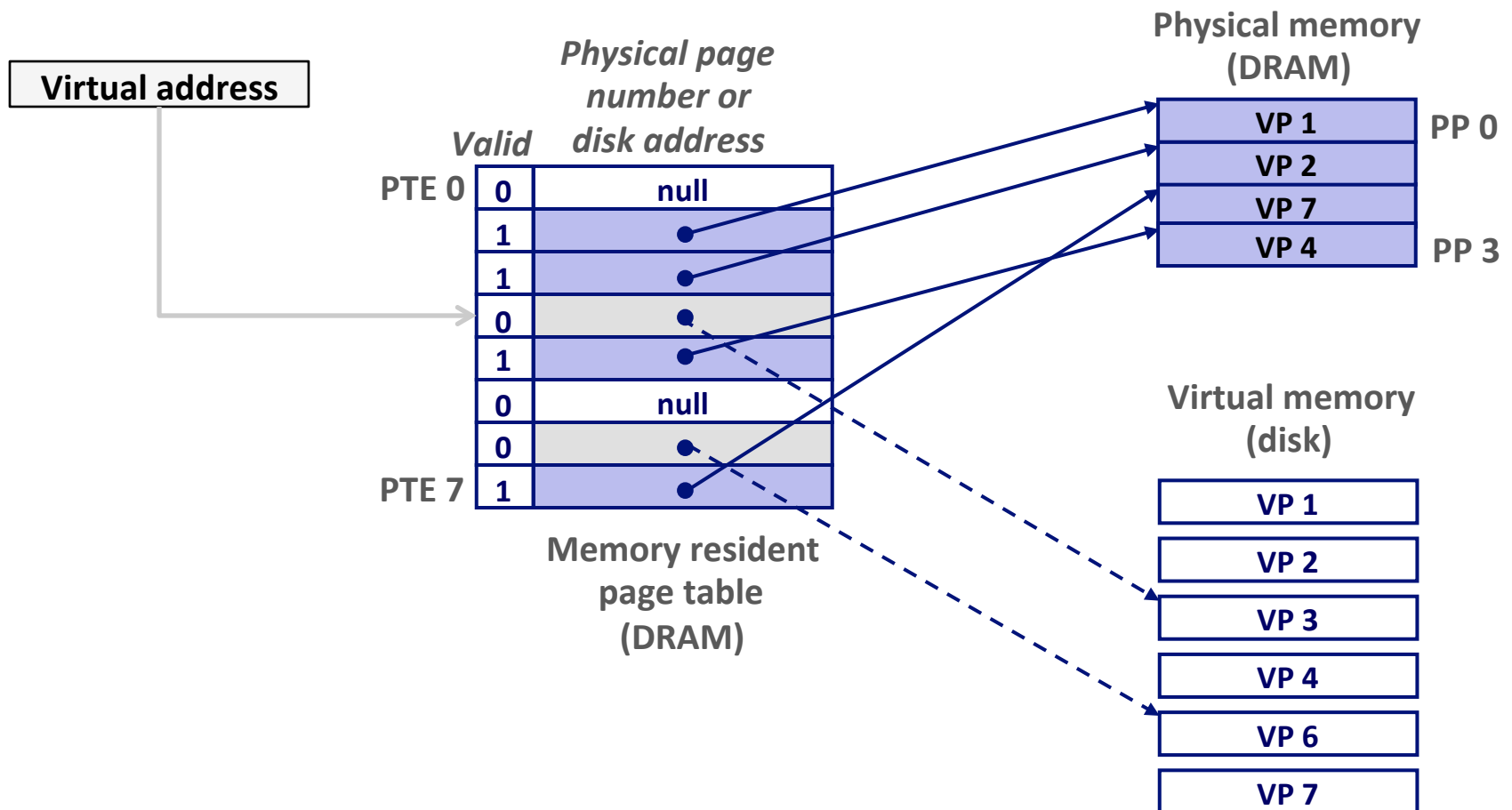

# Handling Page Fault

- Page miss causes page fault (an exception)
- Page fault handler selects a victim to be evicted (here VP 4)

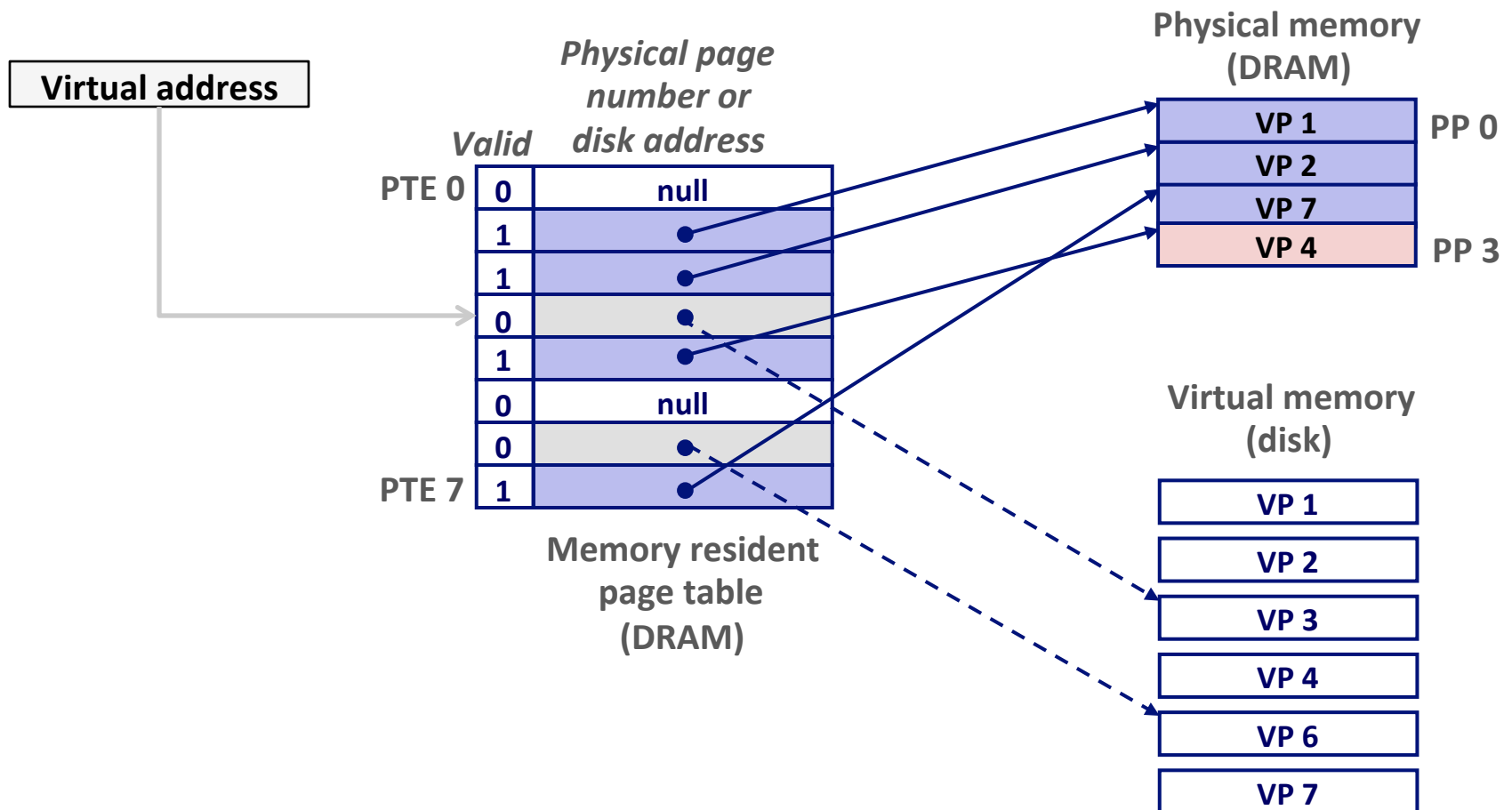

# Handling Page Fault

- Page miss causes page fault (an exception)
- Page fault handler selects a victim to be evicted (here VP 4)

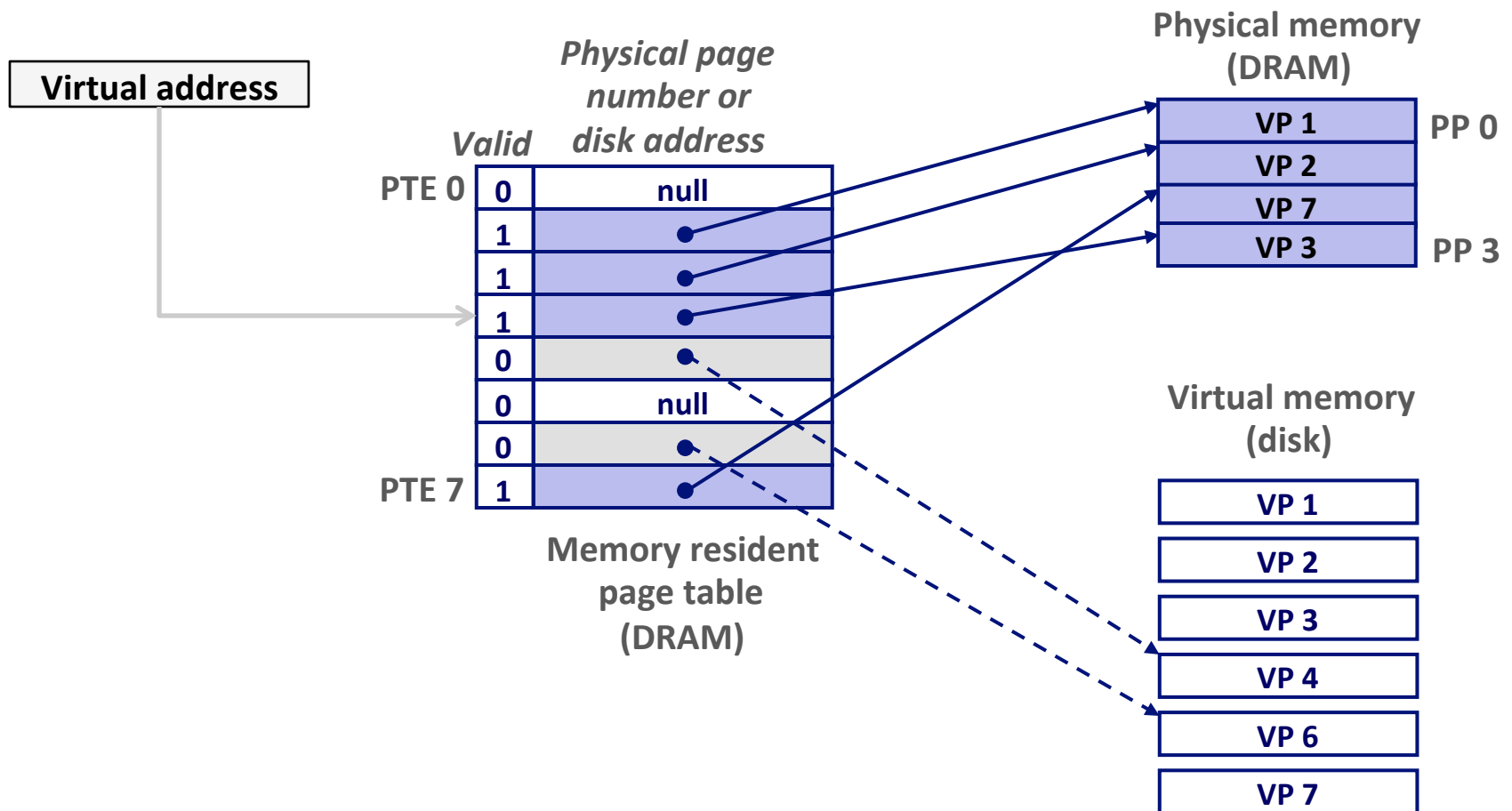

# Handling Page Fault

- Page miss causes page fault (an exception)
- Page fault handler selects a victim to be evicted (here VP 4)
- Offending instruction is restarted: page hit!

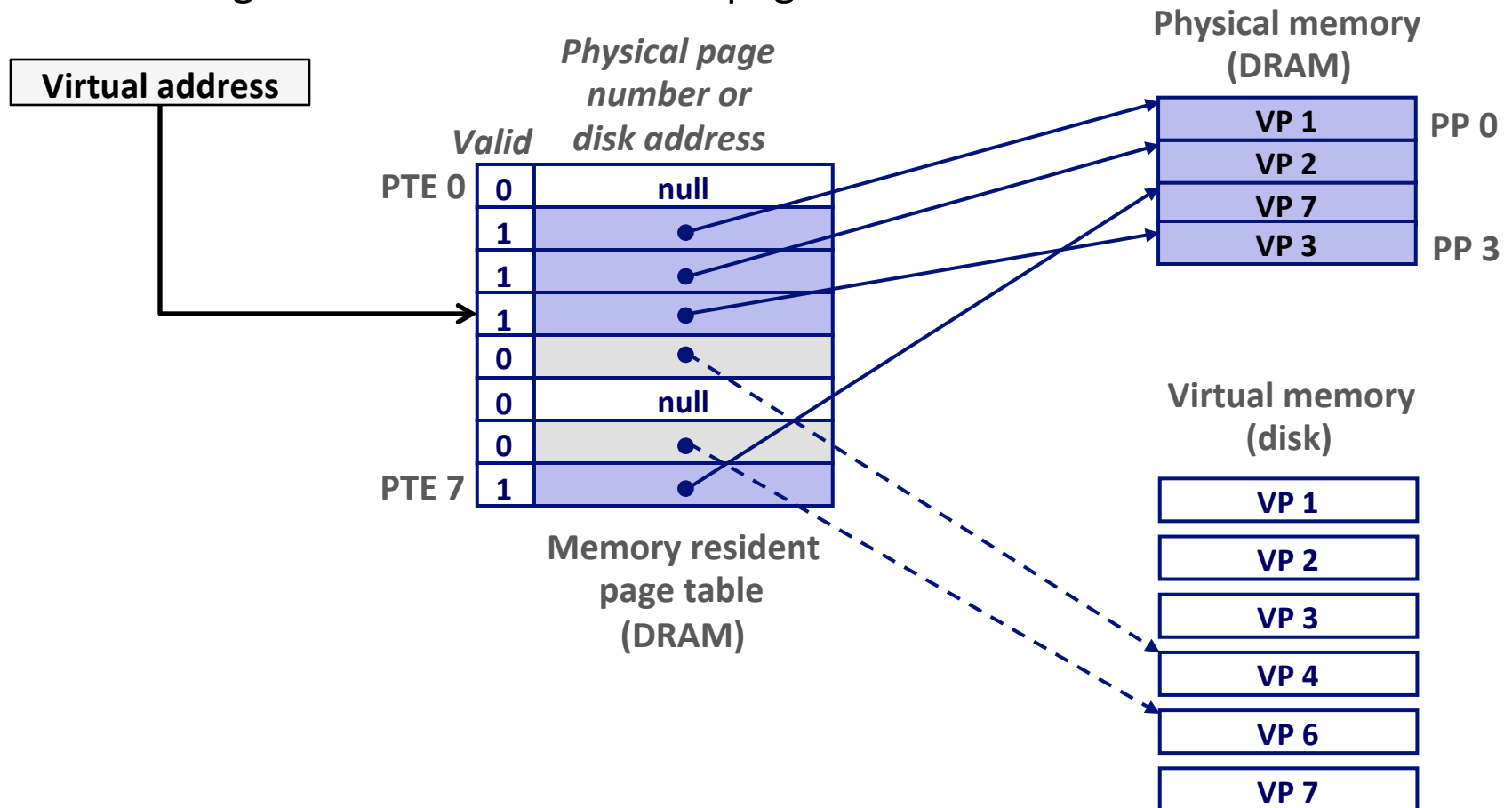



# Locality to the Rescue Again!

- Virtual memory works because of locality
- At any point in time, programs tend to access a set of active virtual pages called the *working set*
  - Programs with better temporal locality will have smaller working sets
- If (working set size < main memory size)
  - Good performance for one process after compulsory misses
- If ( SUM(working set sizes) > main memory size )
  - *Thrashing*: Performance meltdown where pages are swapped (copied) in and out continuously

# Today

- Address spaces
- VM as a tool for caching
- **VM as a tool for memory management**
- VM as a tool for memory protection
- Address translation

# VM as a Tool for Memory Management

- **Key idea: each process has its own virtual address space**
  - It can view memory as a simple linear array
  - Mapping function scatters addresses through physical memory
    - Well chosen mappings simplify memory allocation and management

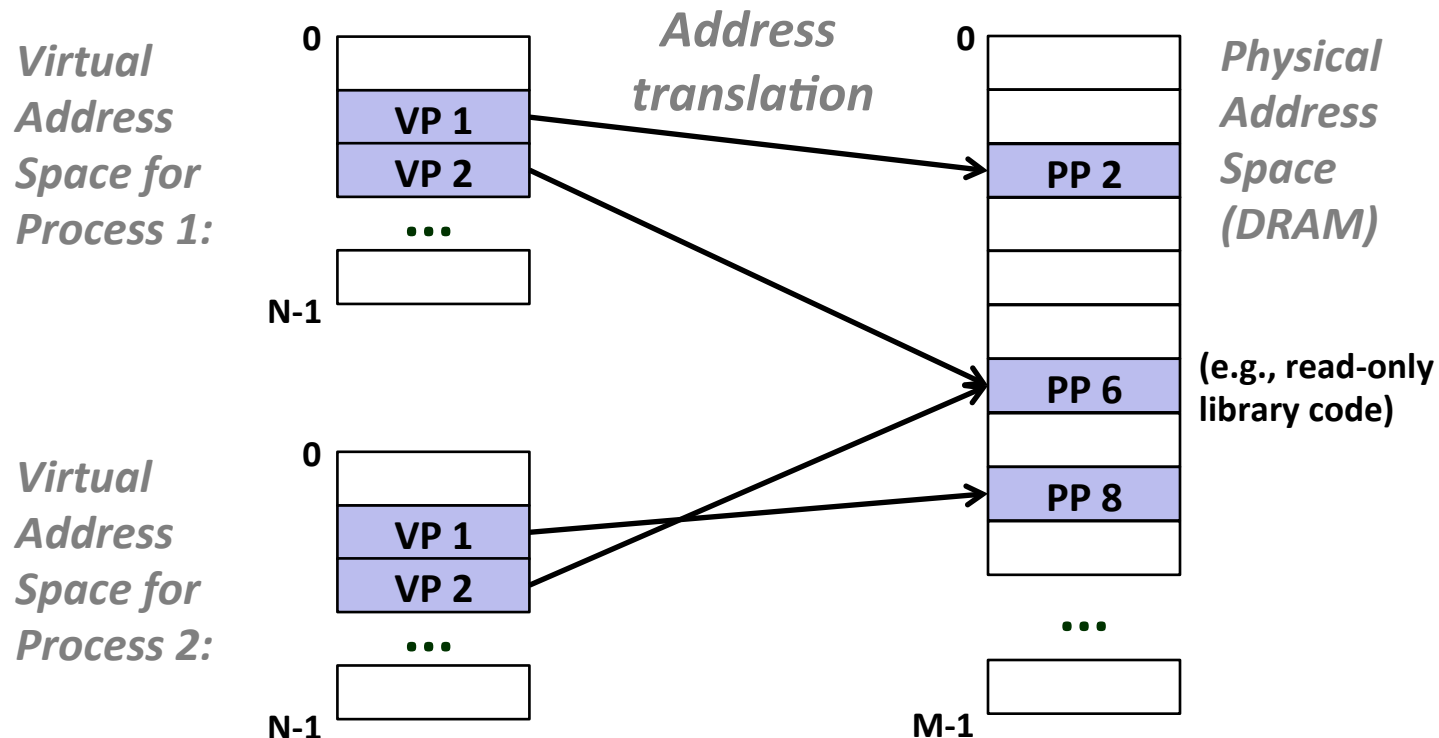

# VM as a Tool for Memory Management

## ■ Memory allocation

- Each virtual page can be mapped to any physical page
- A virtual page can be stored in different physical pages at different times

## ■ Sharing code and data among processes

- Map virtual pages to the same physical page (here: PP 6)

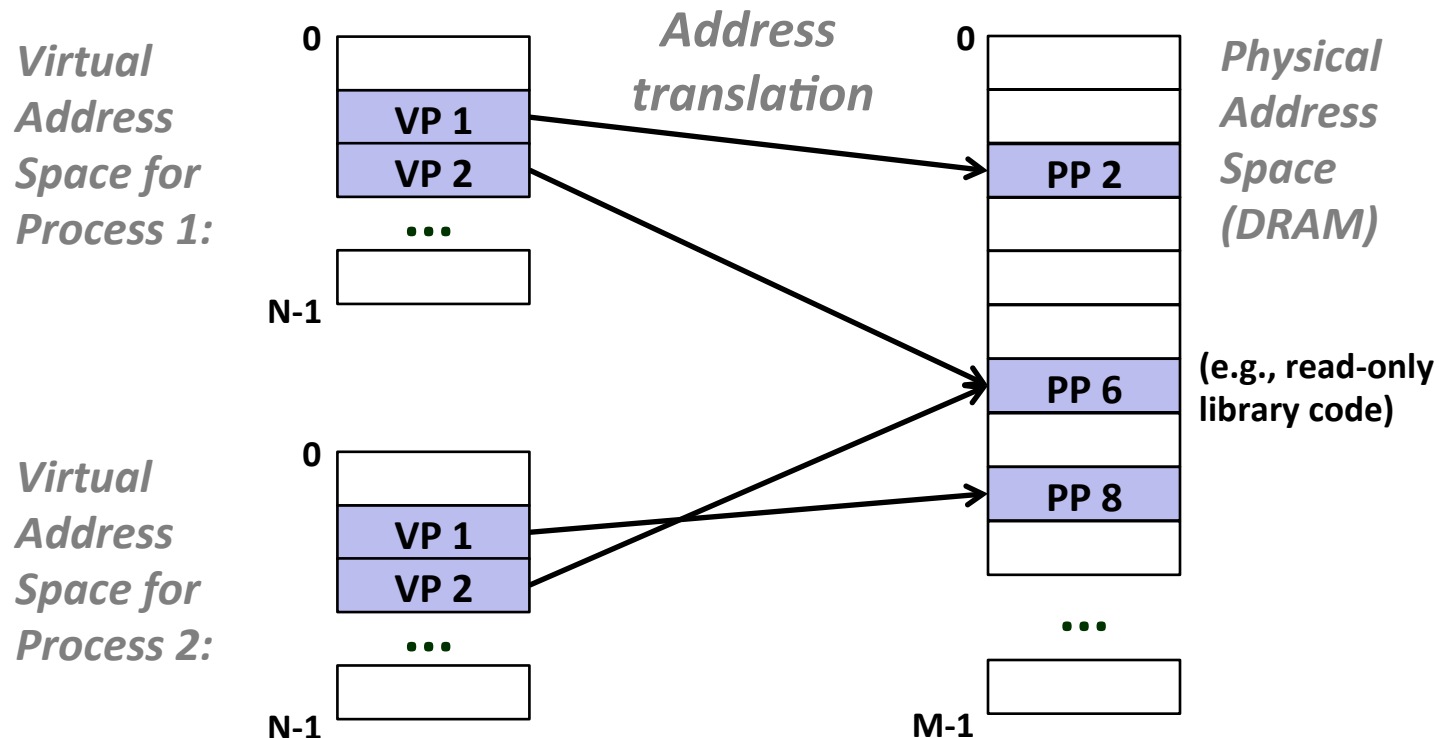

# Simplifying Linking and Loading

## ■ Linking

- Each program has similar virtual address space
- Code, stack, and shared libraries always start at the same address

## ■ Loading

- `execve()` allocates virtual pages for `.text` and `.data` sections = creates PTEs marked as invalid
- The `.text` and `.data` sections are copied, page by page, on demand by the virtual memory system

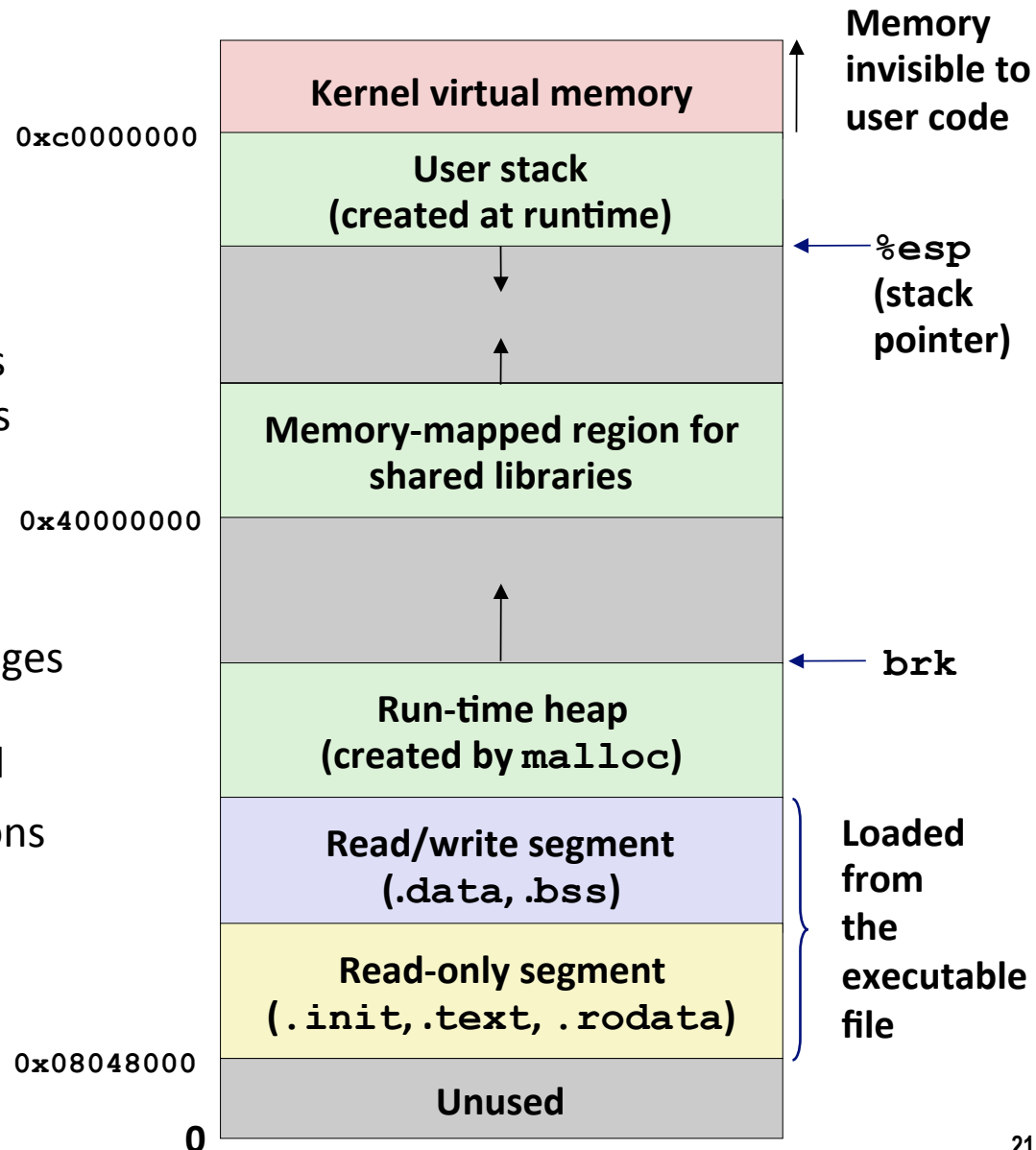

# Today

- Address spaces
- VM as a tool for caching
- VM as a tool for memory management
- **VM as a tool for memory protection**
- Address translation

# VM as a Tool for Memory Protection

- Extend PTEs with permission bits
- Page fault handler checks these before remapping
  - If violated, send process SIGSEGV (segmentation fault)

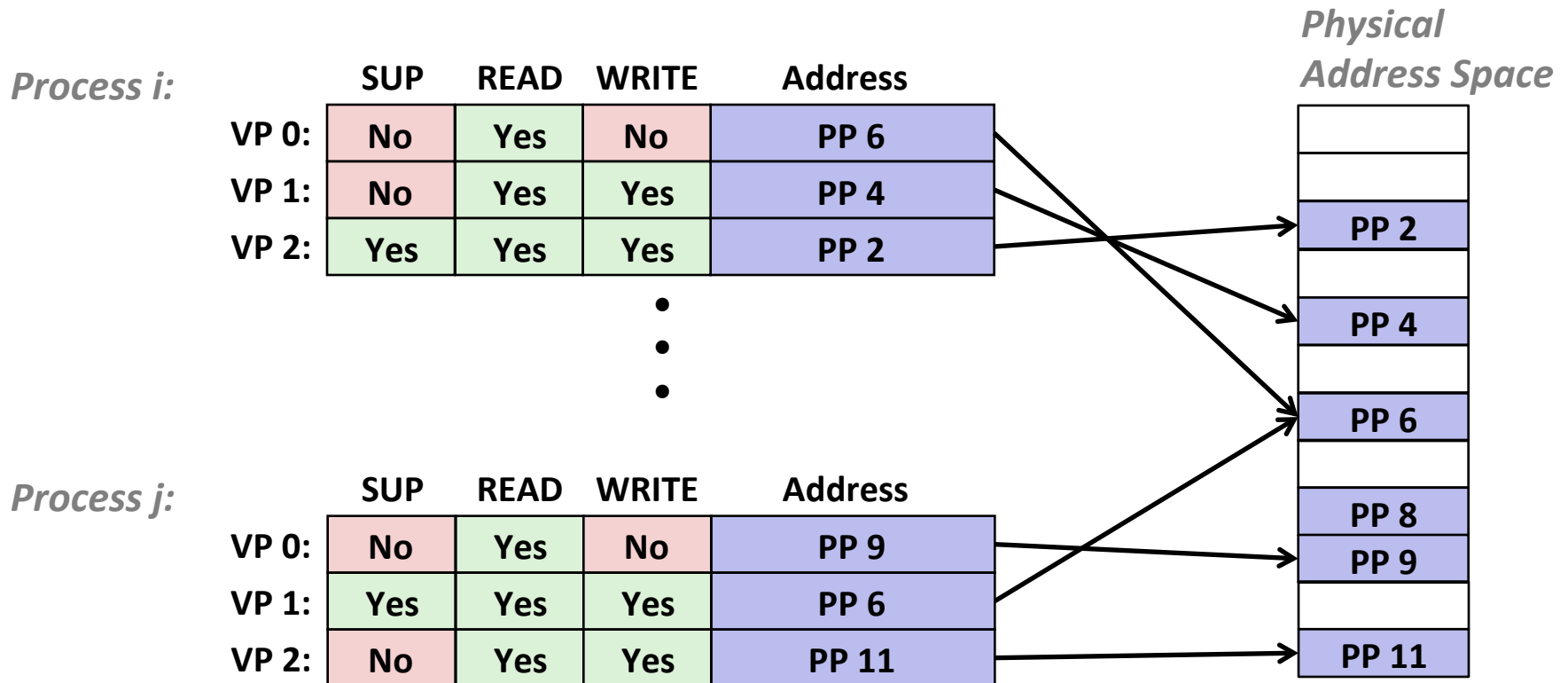

# Today

- Address spaces
- VM as a tool for caching
- VM as a tool for memory management
- VM as a tool for memory protection
- **Address translation**



# VM Address Translation

## ■ Virtual Address Space

- $V = \{0, 1, \dots, N-1\}$

## ■ Physical Address Space

- $P = \{0, 1, \dots, M-1\}$

## ■ Address Translation

- $MAP: V \rightarrow P \cup \{\emptyset\}$

- For virtual address  $a$ :

- $MAP(a) = a'$  if data at virtual address  $a$  is at physical address  $a'$  in  $P$

- $MAP(a) = \emptyset$  if data at virtual address  $a$  is not in physical memory

- Either invalid or stored on disk

# Summary of Address Translation Symbols

## ■ Basic Parameters

- $N = 2^n$  : Number of addresses in virtual address space
- $M = 2^m$  : Number of addresses in physical address space
- $P = 2^p$  : Page size (bytes)

## ■ Components of the virtual address (VA)

- **TLBI**: TLB index
- **TLBT**: TLB tag
- **VPO**: Virtual page offset
- **VPN**: Virtual page number

## ■ Components of the physical address (PA)

- **PPO**: Physical page offset (same as VPO)
- **PPN**: Physical page number
- **CO**: Byte offset within cache line
- **CI**: Cache index
- **CT**: Cache tag

# Address Translation With a Page Table

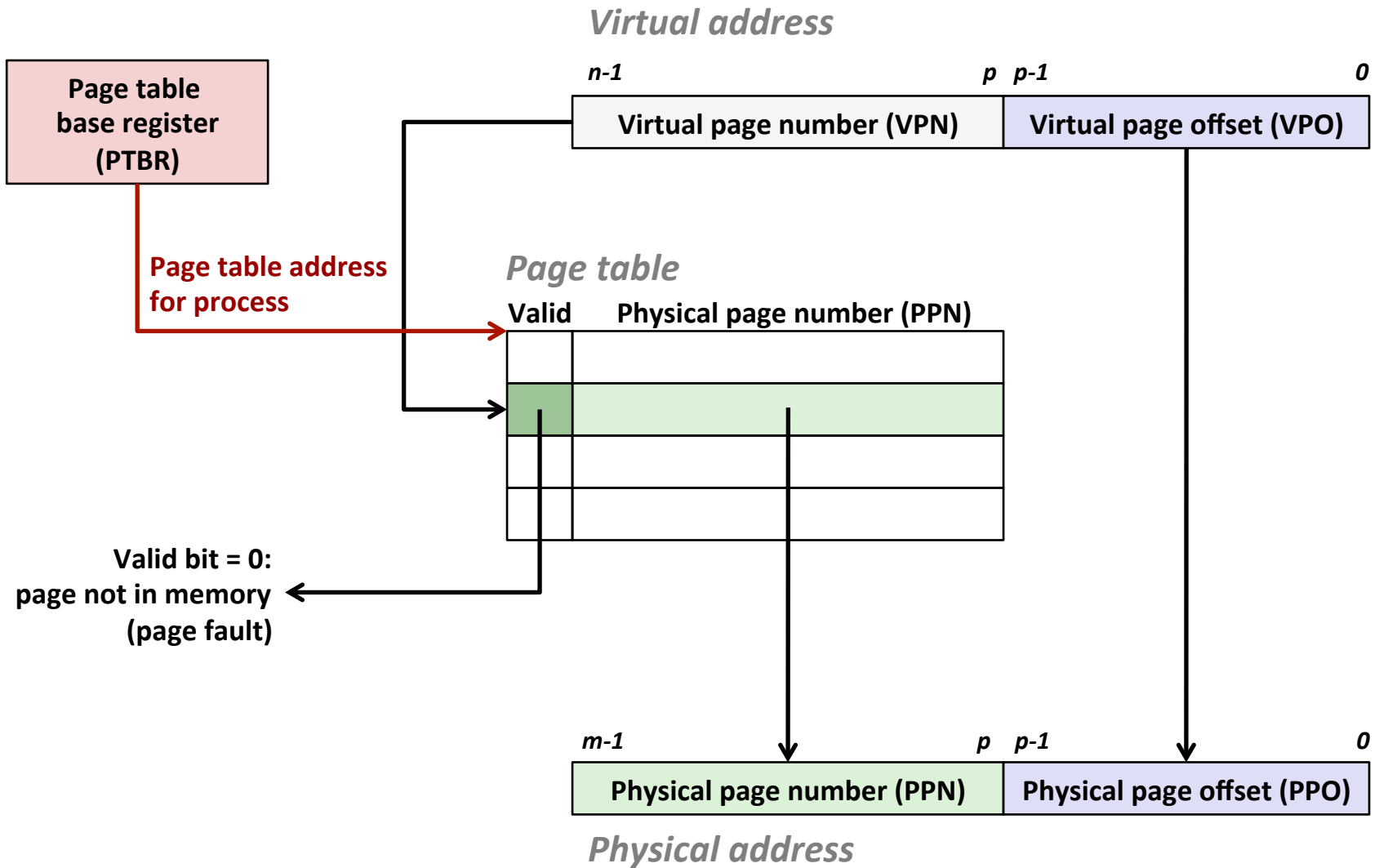

# Address Translation: Page Hit

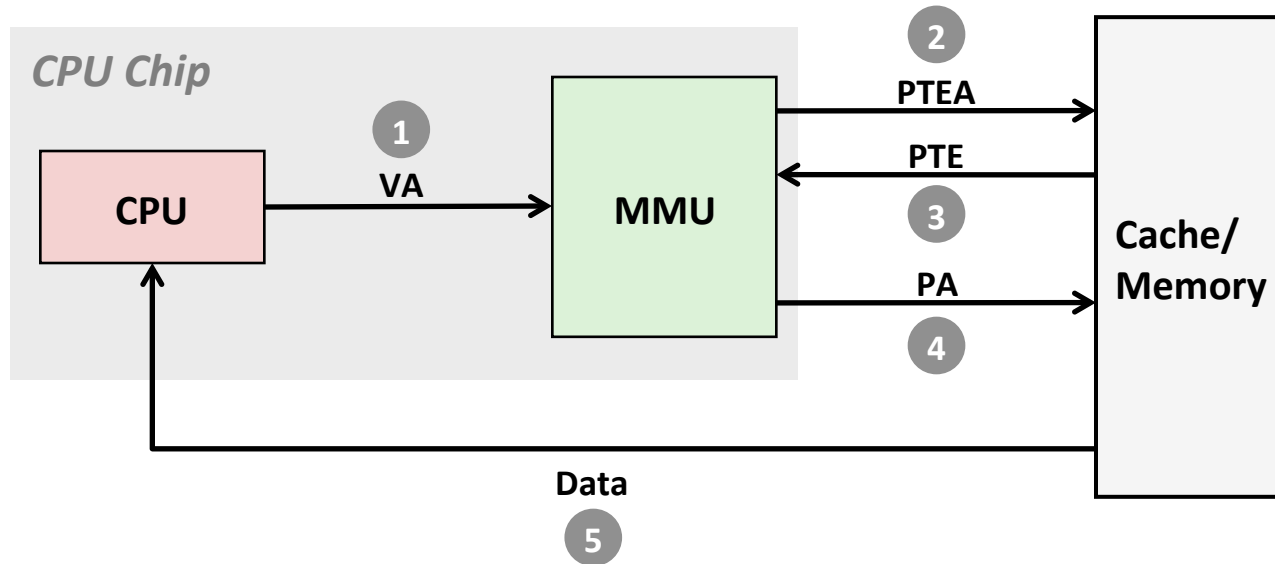

- 1) Processor sends virtual address to MMU
- 2-3) MMU fetches PTE from page table in memory
- 4) MMU sends physical address to cache/memory
- 5) Cache/memory sends data word to processor

# Address Translation: Page Fault

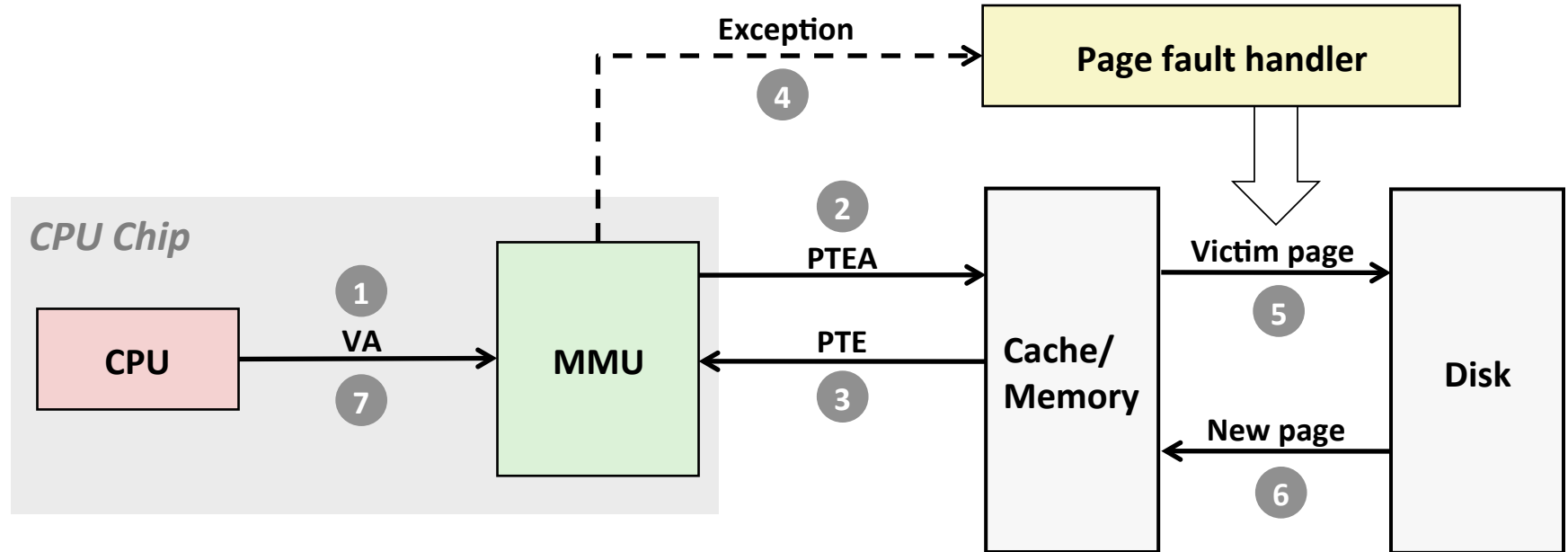

- 1) Processor sends virtual address to MMU
- 2-3) MMU fetches PTE from page table in memory
- 4) Valid bit is zero, so MMU triggers page fault exception
- 5) Handler identifies victim (and, if dirty, pages it out to disk)
- 6) Handler pages in new page and updates PTE in memory
- 7) Handler returns to original process, restarting faulting instruction

# Integrating VM and Cache

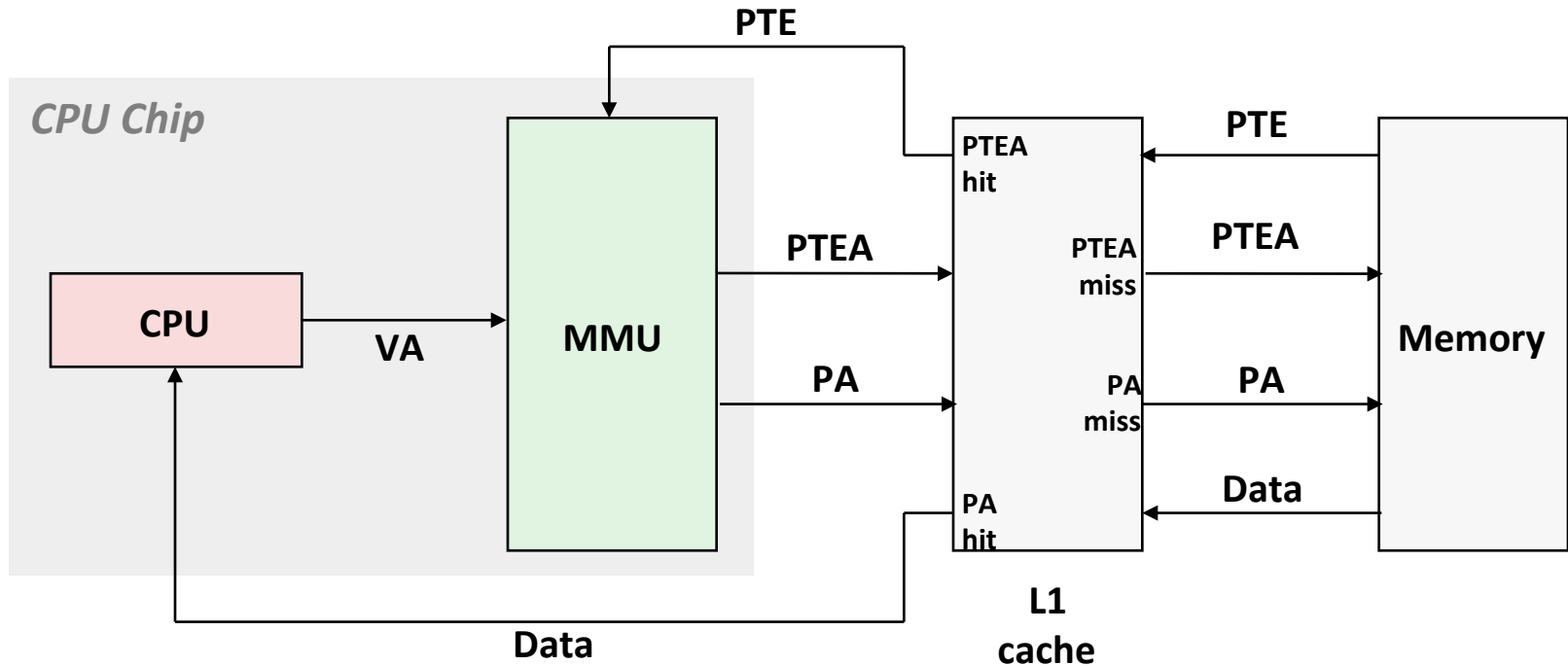

*VA: virtual address, PA: physical address, PTE: page table entry, PTEA = PTE address*

# Speeding up Translation with a TLB

- **Page table entries (PTEs) are cached in L1 like any other memory word**
  - PTEs may be evicted by other data references
  - PTE hit still requires a small L1 delay
- **Solution: *Translation Lookaside Buffer* (TLB)**
  - Small hardware cache in MMU
  - Maps virtual page numbers to physical page numbers
  - Contains complete page table entries for small number of pages

# TLB Hit

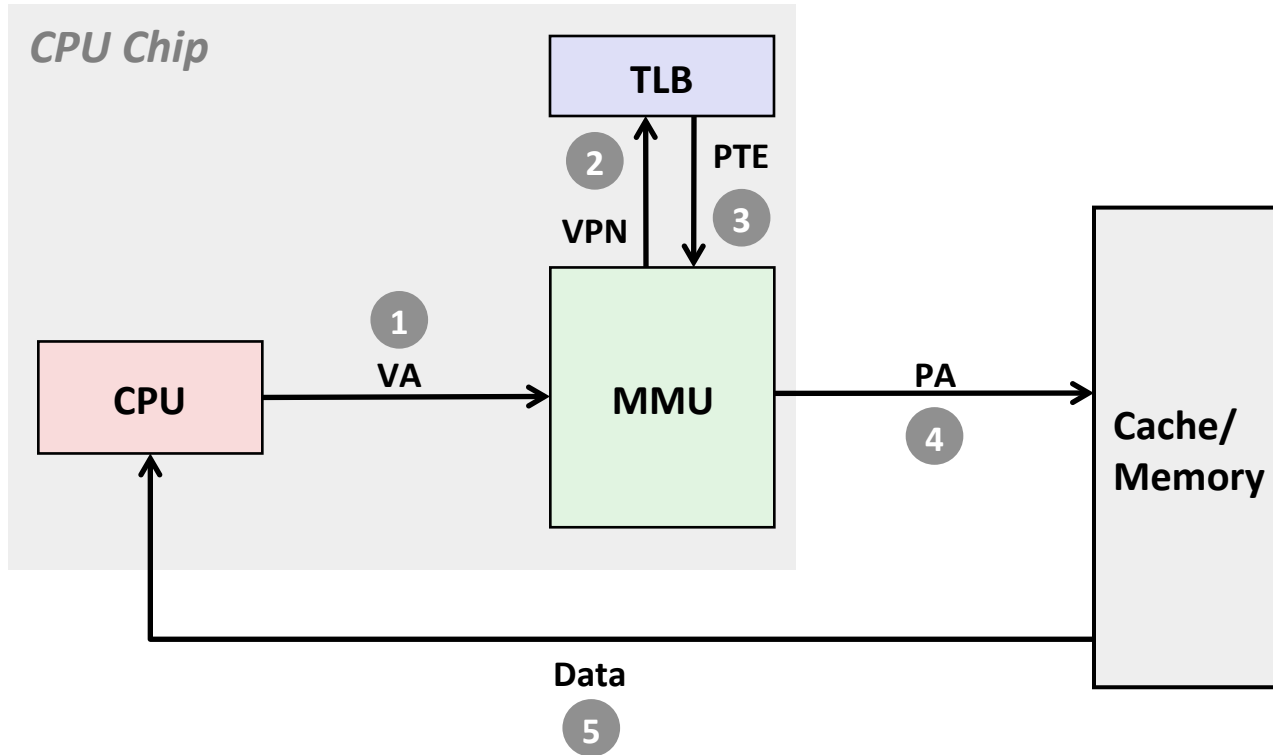

**A TLB hit eliminates a memory access**



# TLB Miss

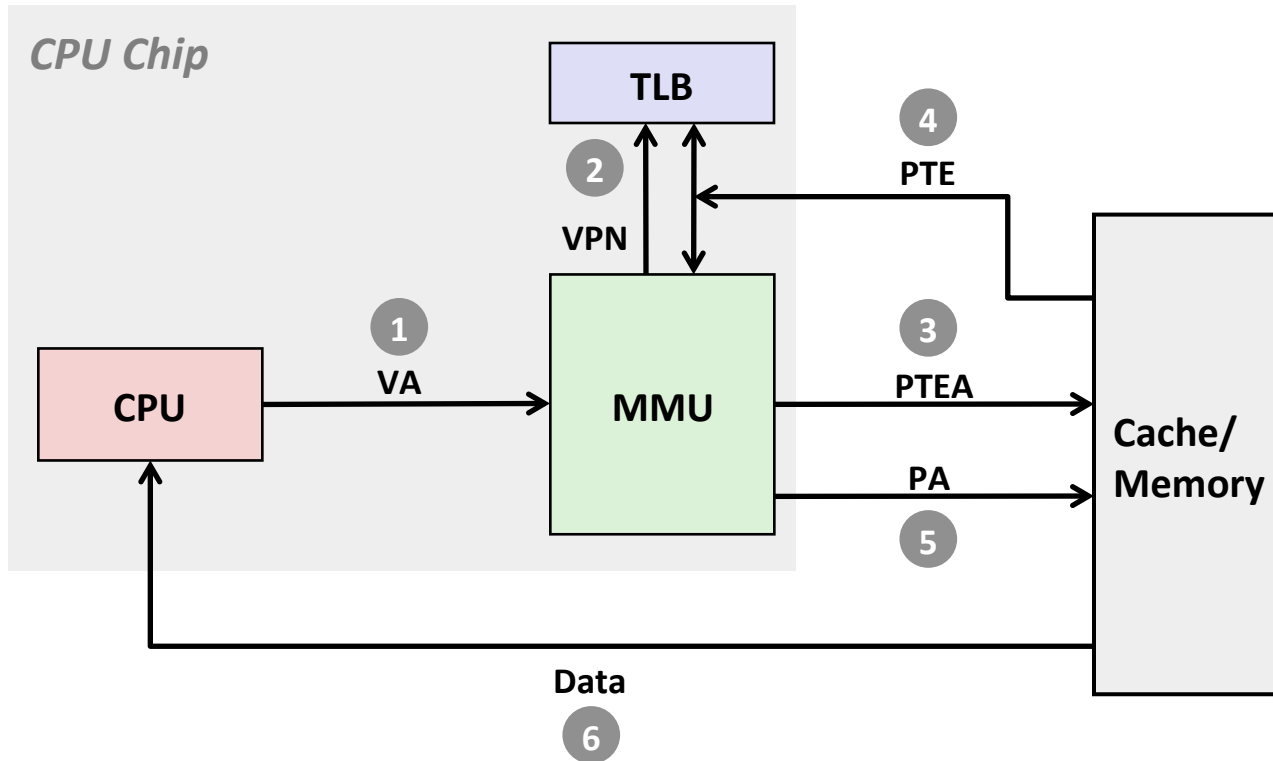

**A TLB miss incurs an additional memory access (the PTE)**

Fortunately, TLB misses are rare. Why?

# Multi-Level Page Tables

## ■ Suppose:

- 4KB ( $2^{12}$ ) page size, 48-bit address space, 8-byte PTE

## ■ Problem:

- Would need a 512 GB page table!
  - $2^{48} * 2^{-12} * 2^3 = 2^{39}$  bytes

## ■ Common solution:

- Multi-level page tables
- Example: 2-level page table
  - Level 1 table: each PTE points to a page table (always memory resident)
  - Level 2 table: each PTE points to a page (paged in and out like any other data)

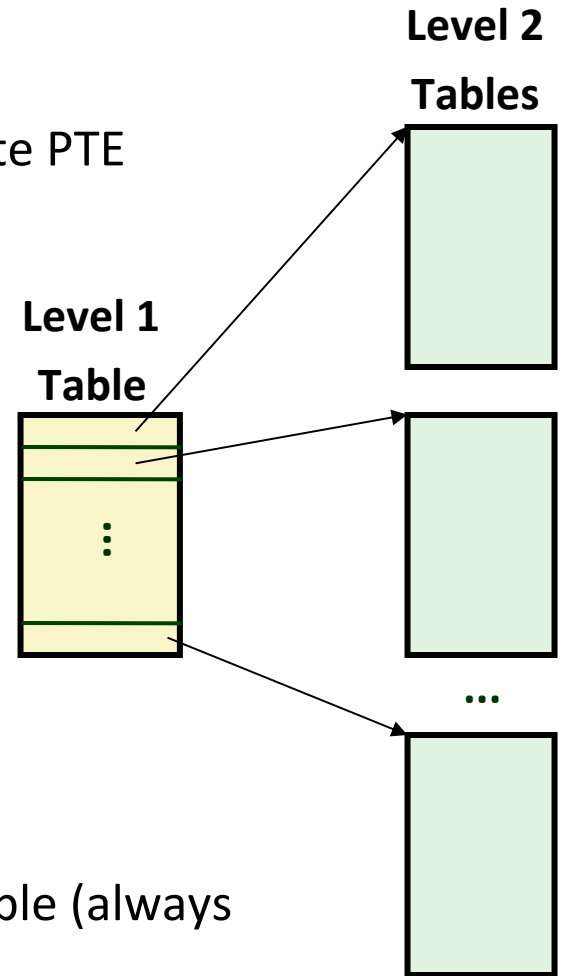

# A Two-Level Page Table Hierarchy

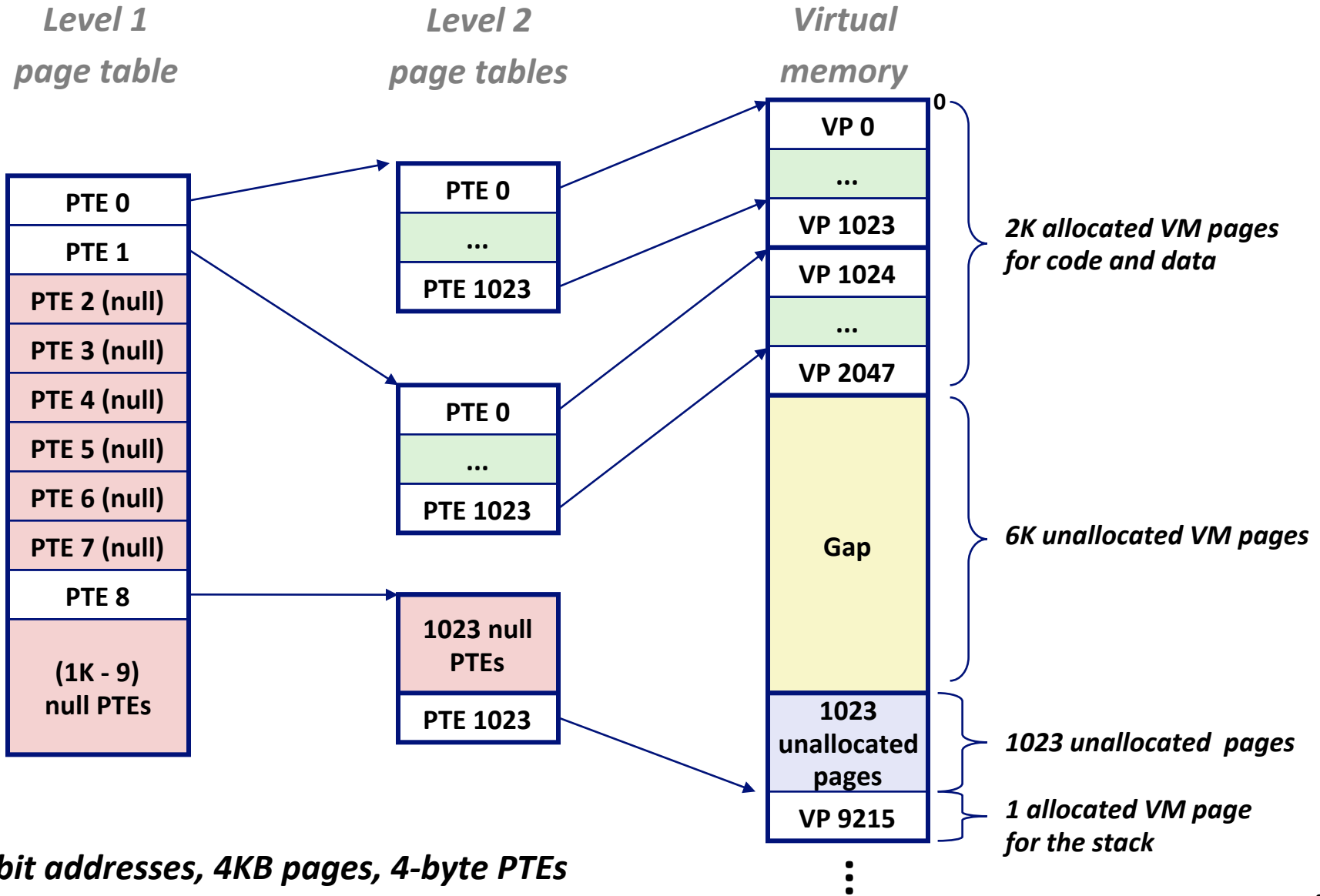

# General k-Level Page Table

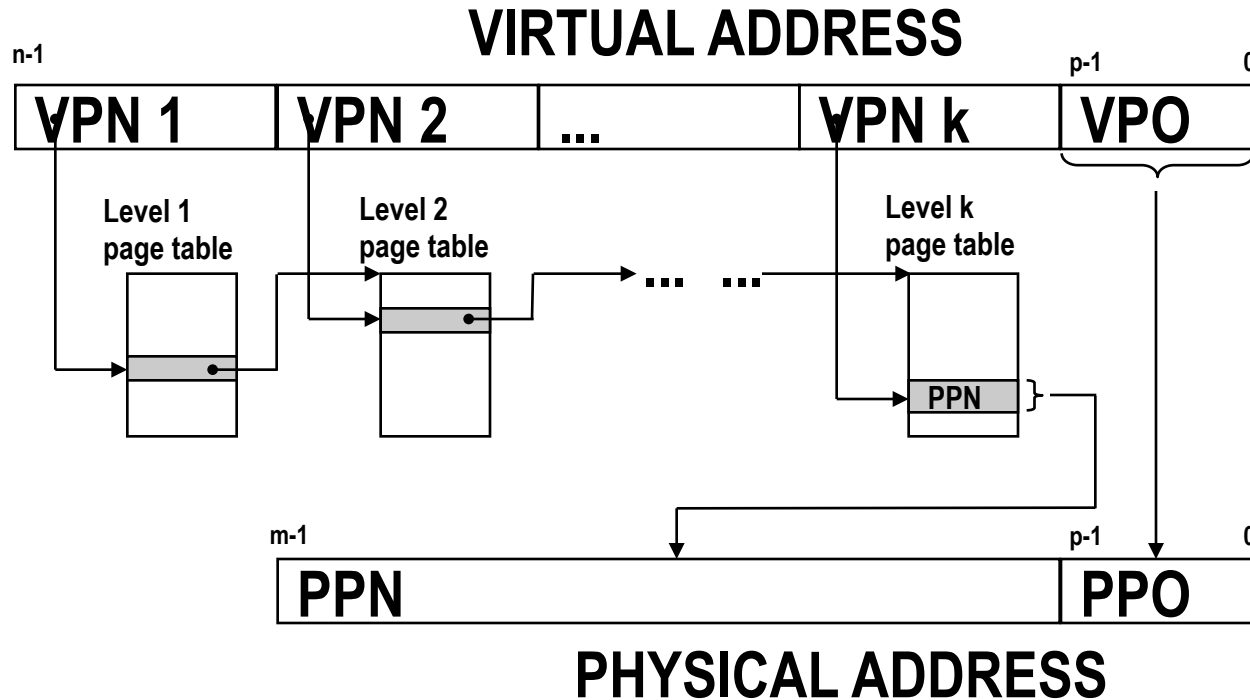

- Same principle as before.

# Summary

## ■ Programmer's view of virtual memory

- Each process has its own private linear address space
- Cannot be corrupted by other processes

## ■ System view of virtual memory

- Uses memory efficiently by caching virtual memory pages
  - Efficient only because of locality
- Simplifies memory management and programming
- Simplifies protection by providing a convenient interpositioning point to check permissions